



Last name:

First name:

Student number:

# Question 1)

Points: .....

Maximum points: 11

a) Fill out all empty fields.

*(Please fill in each empty cell only one correct answer!)*

## ISO/OSI Reference Model

	Layer	Protocol	Device	Sort of Data (data unit)	Addresses
7	Application Layer	SMTP		Message	
6	Presentation Layer				
5	Session Layer				
4	Transport Layer	TCP, UDP	(VPN-)Gateway	Segment	Port number
3	Network Layer	IP, ICMP	Router, L3-Switch	Packet	IP address
2	Data Link Layer	Ethernet, Wifi, Bluetooth, PPP...	Bridge, L2-Switch, Modem	Frame	MAC address
1	Presentation Layer	Ethernet, Wifi, Bluetooth...	Repeater, Hub	Signal	

Last name:

First name:

Student number:

---

## Question 2)

Points: .....

Maximum points: 3

a) The following information come from existing twisted pair network cables. What information is provided about the shielding of these cables?

- E138922 RU AWM 2835 24 AWG 60°C CSA LL81295 FT2 ETL VERIFIED  
EIA/TIA-568A CAT.5 UTP EVERNEW G3C511

*UTP = Unshielded Twisted Pair*

- E188601 (UL) TYPE CM 75°C LL84201 CSA TYPE CMG FT4 CAT.5E PATCH  
CABLE TO TIA/EIA 568A STP 26AWG STRANDED

*STP = Shielded Twisted Pair*

- E324441 RU AWM 2835 24AWG 60°C 30V CHANGJIANG TIA/EIA 568B.2 UTP  
CAT.5e

*UTP = Unshielded Twisted Pair*

- SSTP ENHANCED CAT.5 350MHZ 26AWG X 4P PATCH TYPE CM (UL) C(UL)  
E200579 CMG CSA LL81924 3P VERIFIED

*SSTP = Screened Shielded Twisted Pair*

- EC-net 7.5 m 11184406 13/03 PremiumNet 4 PAIR 26AWG S-FTP HF  
IEC 332-1 ENHANCED CATEGORY 5 PATCH CORD EN0173+ISO/IEC

*SFTP = Screened Foiled Twisted Pair*

- (UL) E228252 TYPE CM 75°C 24AWG 4PR UTP C(UL) E228252 CMR 73°C ETL  
VERIFIED TIA/EIA 568B.2 CAT.5e

*UTP = Unshielded Twisted Pair*

Last name:

First name:

Student number:

---

## Question 3)

Points: .....

Maximum points: 4

Calculate the first and last host addresses, the network address and the broadcast address of the subnet.

IP Address:	130.120.20.123	10000010.01111000.00010100.01111011
Subnet mask:	255.255.240.0	11111111.11111111.11110000.00000000
Part for host IDs:		xxxx.xxxxxxxxxx
Network address?	130.120.16.0	10000010.01111000.00010000.00000000
First host address?	130.120.16.1	10000010.01111000.00010000.00000001
Last host address?	130.120.31.254	10000010.01111000.00011111.11111110
Broadcast address?	130.120.31.255	10000010.01111000.00011111.11111111

binary representation	decimal representation
10000000	128
11000000	192
11100000	224
11110000	240
11111000	248
11111100	252
11111110	254
11111111	255

Last name:

First name:

Student number:

---

## Question 4)

Points: .....

Maximum points:  $2.5+2.5=5$

- a) Split the class B network 189.23.0.0 for implementing 20 subnets. Calculate the subnet mask and answer the questions.

Network ID: 10111101.00010111.00000000.00000000 189.23.0.0  
Number of bits for subnet IDs?  $20 \Rightarrow 32 (= 2^5) \Rightarrow 5$  bits  
Subnet mask: 11111111.11111111.11111000.00000000 255.255.248.0  
Number of bits for host IDs? 11  
Number of host IDs per subnet?  $2^{11} - 2 = 2046$

- b) Split the class B network 129.15.0.0 into subnets, which contain 10 hosts each. Calculate the subnet mask and answer the questions.

Network ID: 10000001.00001111.00000000.00000000 129.15.0.0  
Number of bits for host IDs?  $10 \Rightarrow 16 (= 2^4) \Rightarrow 4$  bits  
Number of bits for subnet IDs?  $16 - 4 = 12$  bit  
Number of possible subnets?  $2^{12} = 4096$   
Subnet mask: 11111111.11111111.11111111.11110000 255.255.255.240

binary representation	decimal representation
10000000	128
11000000	192
11100000	224
11110000	240
11111000	248
11111100	252
11111110	254
11111111	255

Last name:

First name:

Student number:

# Question 5)

Points: .....

Maximum points: 3

This signal curve is encoded with NRZI and 4B5B. Decode the data.

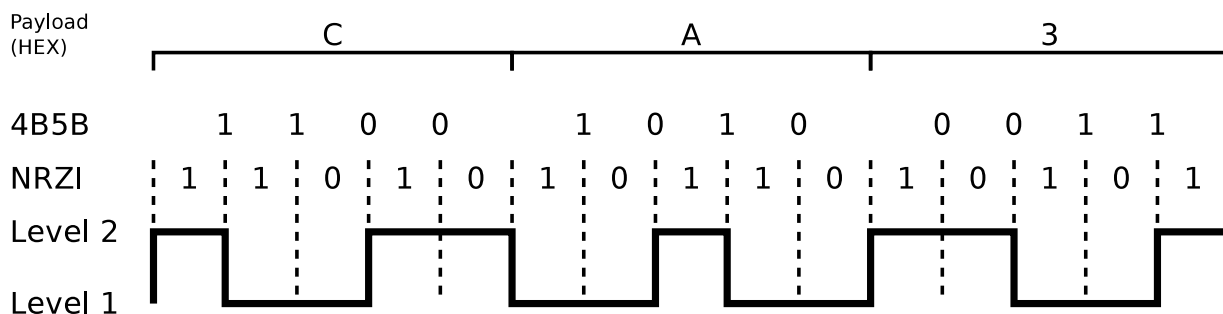

Label	4B	5B	Function
0	0000	11110	0 hexadecimal
1	0001	01001	1 hexadecimal
2	0010	10100	2 hexadecimal
3	0011	10101	3 hexadecimal
4	0100	01010	4 hexadecimal
5	0101	01011	5 hexadecimal
6	0110	01110	6 hexadecimal
7	0111	01111	7 hexadecimal
8	1000	10010	8 hexadecimal
9	1001	10011	9 hexadecimal
A	1010	10110	A hexadecimal
B	1011	10111	B hexadecimal
C	1100	11010	C hexadecimal
D	1101	11011	D hexadecimal
E	1110	11100	E hexadecimal
F	1111	11101	F hexadecimal

Last name:

First name:

Student number:

# Question 6)

Points: .....

Maximum points: 5

Encode the bit sequence with 5B6B and NRZ and draw the signal curve.

Bit sequence: 11010 11110 01001 00010 01110

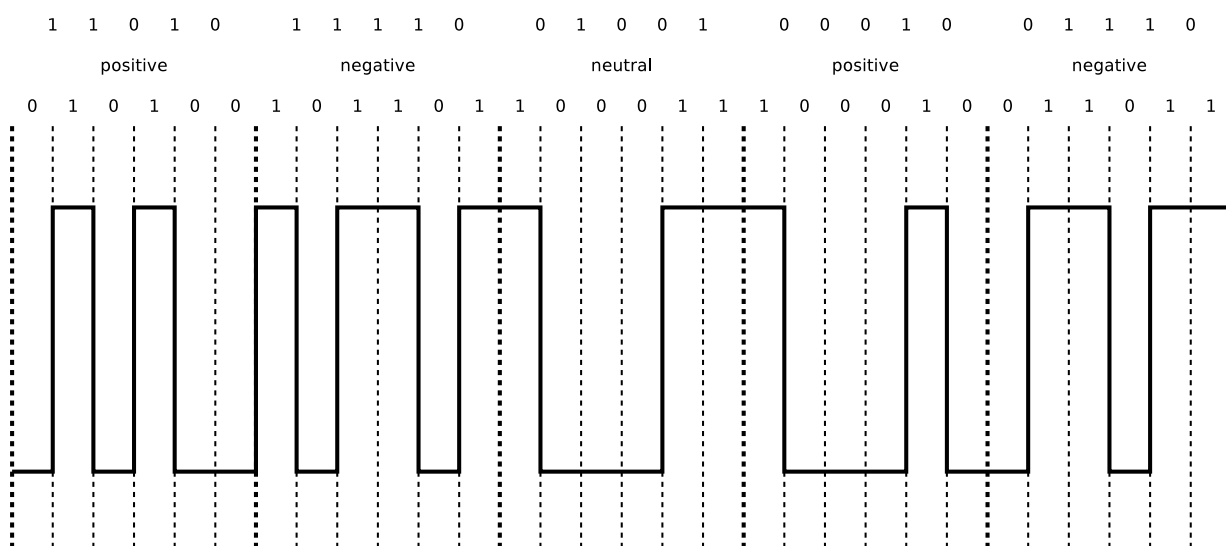

5B	6B neutral	6B positive	6B negative	5B	6B neutral	6B positive	6B negative
00000		001100	110011	10000		000101	111010
00001	101100			10001	100101		
00010		100010	101110	10010		001001	110110
00011	001101			10011	010110		
00100		001010	110101	10100	111000		
00101	010101			10101		011000	100111
00110	001110			10110	011001		
00111	001011			10111		100001	011110
01000	000111			11000	110001		
01001	100011			11001	101010		
01010	100110			11010		010100	101011
01011		000110	111001	11011	110100		
01100		101000	010111	11100	011100		
01101	011010			11101	010011		
01110		100100	011011	11110		010010	101101
01111	101001			11111	110010		

Last name:

First name:

Student number:

## Question 7)

Points: .....

Maximum points: 6

The figure shows the physical connections of a network. All Bridges boot up at the same time after a power failure. Highlight in the figure which ports and Bridges are not used when the Spanning Tree Protocol is used.

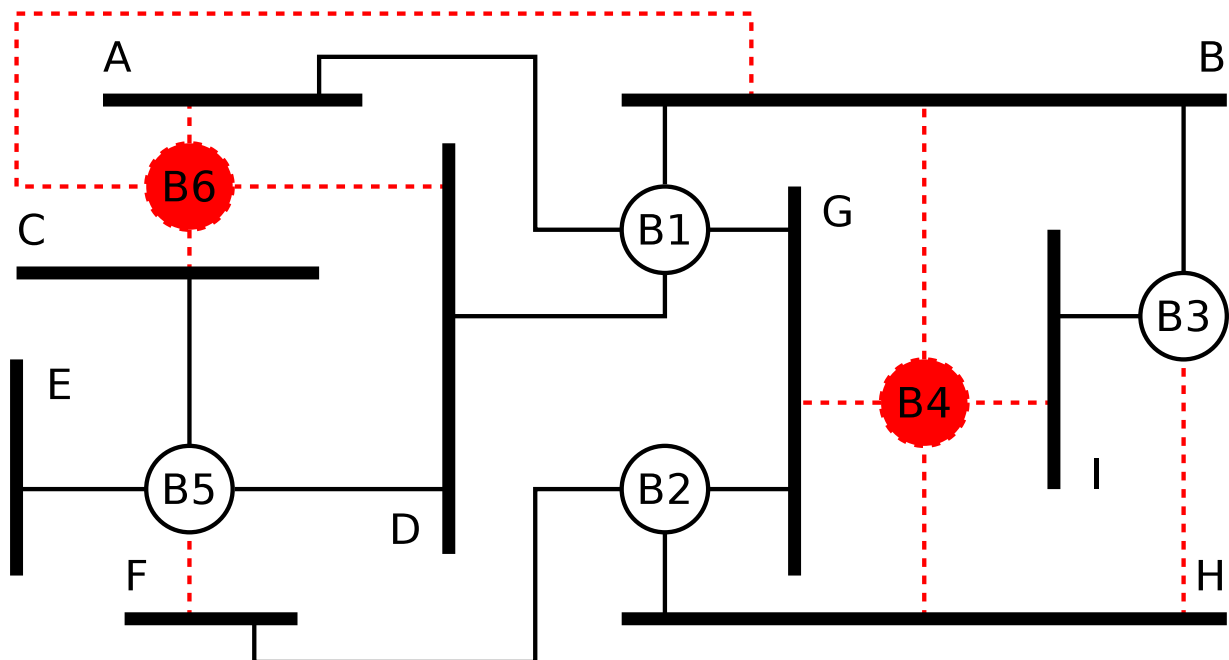



Last name:

First name:

Student number:

---

# Question 8)

Points: .....

Maximum points: 4+4=8

- a) Error detection via CRC: Calculate the frame to be transferred.

Generator polynomial: 100101

Payload: 11010011

*The generator polynomial has 6 digits  $\implies$  five 0 bits are appended*

```

1101001100000 = Frame with appended 0 bits
XOR 100101|||||
-----v|||||
    100011|||||
XOR 100101|||||
-----vvv|||
    110100|||
XOR 100101|||
-----v||
    100010||
XOR 100101||
-----v
    11100 = Remainder

```

Transferred frame: 1101001111100

- b) Error detection via CRC: Check, if the received frame was transmitted correctly.

Transferred frame: 1011010110100

Generator polynomial: 100101

```

1011010110100 = Received frame
XOR 100101|||||
-----vv|||||
    100001|||||
XOR 100101|||||
-----vvv||
    100101||
XOR 100101||
-----v
    00 => Transmission was error-free

```

Last name:

First name:

Student number:

---

## Question 9)

Points: .....

Maximum points: 3+4=7

- a) Error Correction via simplified Hamming Distance (Hamming ECC method). Calculate the message, that will be transmitted (payload inclusive parity bits).

Payload: 10011010

	Position:	1	2	3	4	5	6	7	8	9	10	11	12
Data to be transmitted:		?	?	1	?	0	0	1	?	1	0	1	0

```
0011 Position 3
0111 Position 7
1001 Position 9
XOR 1011 Position 11
-----
```

0110 = parity bit values

	Position:	1	2	3	4	5	6	7	8	9	10	11	12
Data to be transmitted:		0	1	1	1	0	0	1	0	1	0	1	0

- b) Error Correction via simplified Hamming Distance (Hamming ECC method). Verify, if the received message was transmitted correctly.

Received message: 0001101100101101

	Position:	1	2	3	4	5	6	7	8	9	10	11	12	13	14	15	16
Received data:		0	0	0	1	1	0	1	1	0	0	1	0	1	1	0	1

```
00101 Position 5
00111 Position 7
01011 Position 11
01101 Position 13
XOR 01110 Position 14
-----
```

```
01010 Parity bits calculated
XOR 00111 Parity bits received
-----
```

01101 => Bit 13 ist defective!

Last name:

First name:

Student number:

# Question 10)

Points: .....

Maximum points: 10

a) Sketch in the diagram of the network topology all collision domains.

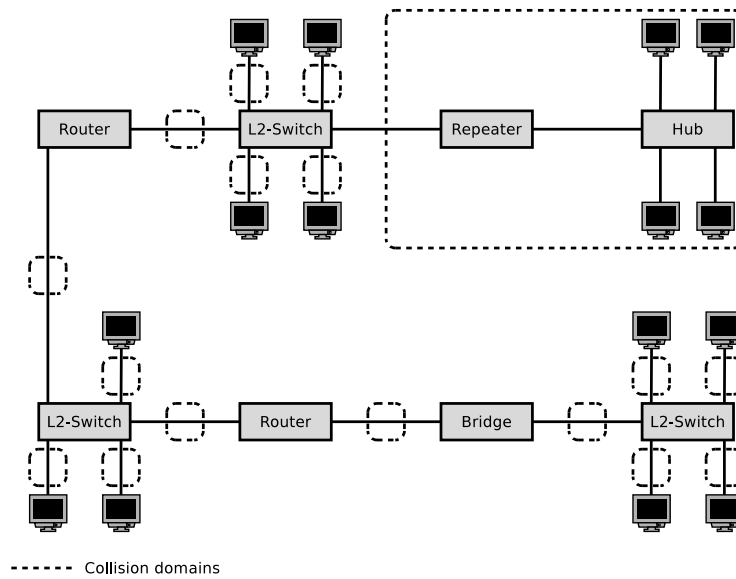

b) Sketch in the diagram of the network topology all broadcast domains.

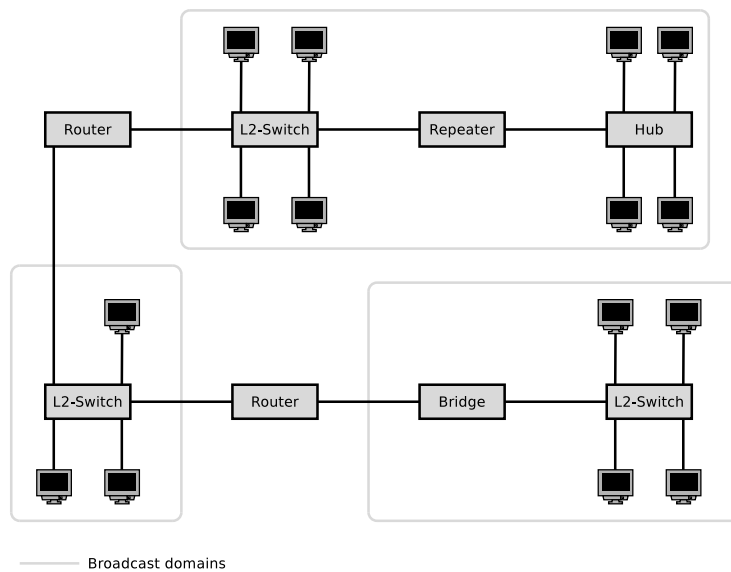

Last name:

First name:

Student number:

---

# Question 11)

Points: .....

Maximum points: 6

The diagram shows an excerpt of the transmission phase of a TCP connection. Complete the table.

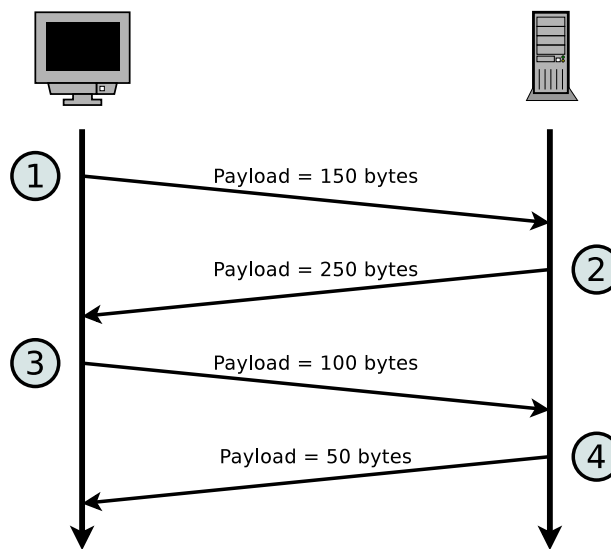

Message	ACK	SYN	FIN	Payload length	Seq number	Ack number
1	0	0	0	150	1800	2500
2	1	0	0	250	2500	1850
3	1	0	0	200	1850	2750
4	1	0	0	50	2750	2050

Last name:

First name:

Student number:

---

## Question 12)

Points: .....

Maximum points: 1+1+1+1+1=5

- a) Mark the IP address of the Default Gateway in the output of `route -n`.

```
# route -n
Kernel IP routing table
Destination Gateway Genmask Flags Metric Ref Use Iface
0.0.0.0 192.168.0.1 0.0.0.0 UG 1024 0 0 eth0
192.168.0.0 0.0.0.0 255.255.255.0 U 0 0 0 eth0

192.168.0.1
```

- b) Mark the MAC address of the Default Gateway in the output of `arp -n`.

```
# arp -n
192.168.0.191 ether 00:11:32:1c:03:f3 C eth0
192.168.0.21 ether 1c:b0:94:c4:a2:74 C eth0
192.168.0.1 ether 08:96:d7:2a:c6:06 C eth0

08:96:d7:2a:c6:06
```

- c) The `ifconfig` tool says the local IP address is 192.168.150.71, but the website [checkip.dyndns.org](http://checkip.dyndns.org) says the current IP address is 194.94.82.237. What technology is probably used?

*Network Address Translation (NAT)*

- d) What specifies the Maximum Transmission Unit (MTU)?

*The Maximum Transmission Unit (MTU) specifies the maximum payload of a frame (and thus the maximum size of an IP packet too).*

- e) Given the following configuration, what will happen if you send UDP segments with length 2500 Bytes via `eth0` from this machine?

```
# ifconfig eth0
eth0 Link encap:Ethernet HWaddr B8:27:EB:CE:50:E2
      inet addr:10.0.0.9 Bcast:10.0.0.255 Mask:255.255.255.0
      UP BROADCAST RUNNING MULTICAST MTU:1500 Metric:1
      RX packets:6853190 errors:0 dropped:370 overruns:0 frame:0
      TX packets:3453175 errors:0 dropped:0 overruns:0 carrier:0
      collisions:0 txqueuelen:1000
      RX bytes:1516614221 (1.4 GiB) TX bytes:306452639 (292.2 MiB)
```

*IP Fragmentation is used.*

Last name:

First name:

Student number:

## Question 13 – Part 1/2) Points: .....

Maximum points: 4.5+8+1+3.5=17

Figure 1: Network topology

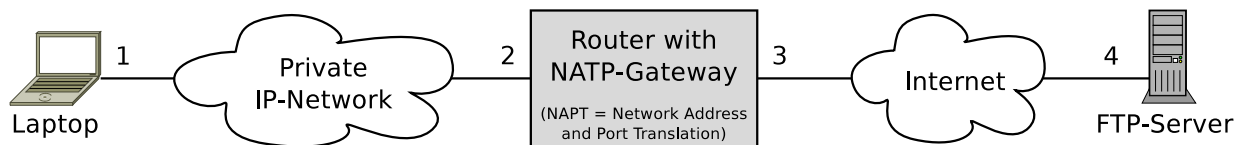

Figure 2: Wireshark output of a received transmission on interface 1

```
⊠ Ethernet II, Src: JuniperN_7a:d6:81 (50:c5:8d:7a:d6:81), Dst: ActionSt_0b:2a:ed (00:24:9b:0b:2a:ed)
⊠ Internet Protocol Version 4, Src: 217.160.233.106, Dst: 192.168.50.17
  0100 .... = Version: 4
  .... 0101 = Header Length: 20 bytes (5)
⊠ Differentiated Services Field: 0x00 (DSCP: CS0, ECN: Not-ECT)
  Total Length: 75
  Identification: 0x1eb4 (7860)
⊠ Flags: 0x00
  Fragment offset: 0
  Time to live: 56
  Protocol: TCP (6)
⊠ Header checksum: 0xae34 [validation disabled]
  Source: 217.160.233.106
  Destination: 192.168.50.17
⊠ Transmission Control Protocol, Src Port: 21 (21), Dst Port: 4934 (4934), Seq: 24, Ack: 11, Len: 35
⊠ File Transfer Protocol (FTP)
```

Figure 3: Wireshark output of a received transmission on interface 3

```
⊠ Ethernet II, Src: 22:ac:11:45:e3:44 (22:ac:11:45:e3:44), Dst: JuniperN_bb:2e:fa (50:c5:8d:bb:2e:fa)
⊠ Internet Protocol Version 4, Src: 217.160.233.106, Dst: 194.94.80.16
  0100 .... = Version: 4
  .... 0101 = Header Length: 20 bytes (5)
⊠ Differentiated Services Field: 0x00 (DSCP: CS0, ECN: Not-ECT)
  Total Length: 75
  Identification: 0x1eb4 (7860)
⊠ Flags: 0x00
  Fragment offset: 0
  Time to live: 56
  Protocol: TCP (6)
⊠ Header checksum: 0xae34 [validation disabled]
  Source: 217.160.233.106
  Destination: 194.94.80.16
⊠ Transmission Control Protocol, Src Port: 21 (21), Dst Port: 22345 (22345), Seq: 3306717526, Ack: 1149803236, Len: 35
⊠ File Transfer Protocol (FTP)
```

The transmissions in figure 2 and figure 3 correspond with each other because they are used to transport the same FTP data. They transport the reply from the FTP server, which is initiated by a request of the laptop.

Last name:

First name:

Student number:

# Question 13 – Part 2/2) Points: .....

Maximum points: 4.5+8+1+3.5=17

a) Fill out all empty fields of the table.

Interface	1	2	3	4
MAC address	00:24:9b:0b:2a:ed	50:c5:8d:7a:d6:81	50:c5:8d:bb:2e:fa	
IP address	192.168.50.17		194.94.80.16	217.160.233.106
Port number	4934		22345	21

b) Show the protocol stack (starting with OSI layer 2) of the transmission in Figure 3. Fill in the correct number of Bytes of the headers, trailer and payloads. Also name the protocols used. Consider the FTP data as pure payload.

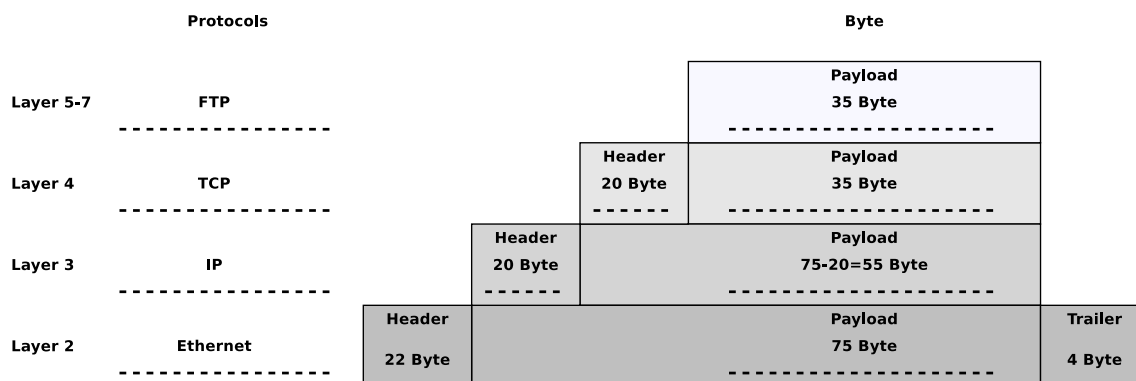

c) What is the amount of overhead in Bytes for the transmission of the FTP data (header and payload)?

$$(22 + 4 + 20 + 20) \text{ Byte} = 66 \text{ Byte}$$

d) Calculate the overhead ratio in % (possible OSI layer 1 overhead is ignored).

$$\text{Size of the transmission} = (75 + 22 + 4) \text{ Byte} = 101 \text{ Byte}$$

$$\text{Overhead (headers and trailer)} = 66 \text{ Byte}$$

$$\text{Overhead ratio} = \frac{66 \text{ Byte}}{101 \text{ Byte}} = 0.6534 * 100\% = 65.35\%$$