

Solution of Exercise Sheet 2

Exercise 1 (Layers of Reference Models)

1. Fill in the names of the layers of the reference models in the figure.

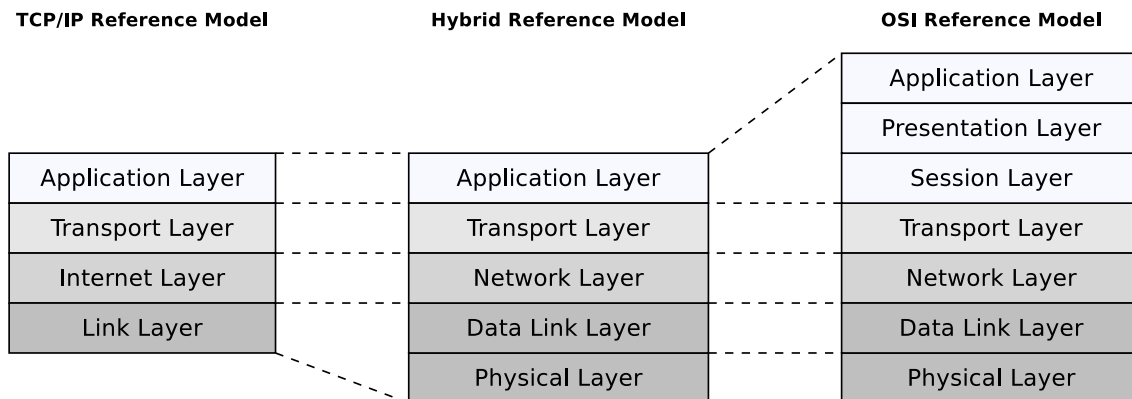

2. Assign to technical terms „Frames“, „Packets“, „Segments“ and „Signals“ to the layers of the reference models in the figure.

Signals \implies Physical Layer

Frames \implies Data Link Layer

Packets \implies Network Layer

Segments \implies Transport Layer

3. Why are the Presentation Layer and the Session Layer not intensively used?

The functionalities, which are intended for the Session Layer and Presentation Layer, are now part of protocols and services in the Application Layer.

4. Why is the hybrid reference model closer to reality, compared with the TCP/IP reference model?

The hybrid reference model illustrates the functioning of computer networks in a realistic way because it distinguishes between the Physical Layer and Data Link Layer and it does not subdivide the Application Layer. It combines the advantages of the TCP/IP reference model and the OSI reference model, without taking over their drawbacks.

Exercise 2 (Transmission Media)

1. Why is the outer conductor (the shield) of **coaxial cables** kept at ground potential and does completely surround the inner conductor?

The shielding of the signal-carrying conductor by the shield, that is kept at ground potential, reduces electromagnetic interferences.

2. What is a **Transceiver**?

Via Transceivers, terminal devices are connected with the transmission medium.

3. What is the purpose of **AUI cables**?

AUI cables are used to connect terminal devices with Transceivers.

4. Why do modern Ethernet standards use **twisted pair cables** with twisted signal wires and not cables with parallel signal wires?

Twisted pairs are better protected against alternating magnetic fields and electrostatic interferences from the outside than parallel signal wires.

5. Show by calculation that regardless of the level of a noise signal, **the difference between the payload signal and the complementary signal remains the same** when using twisted-pair cables. Assume that a signal to be transmitted has an electrical voltage of 0.5 V. This transmission is affected by an interfering signal, which has an electrical voltage of 0.25 V.

$$\begin{aligned} & ((+\text{Payload Signal}) + (\text{Noise})) - ((-\text{Payload Signal}) + (\text{Noise})) \\ & = 2 * \text{Payload Signal} \end{aligned}$$

$$(0.5 \text{ V} + 0.25 \text{ V}) - (-0.5 \text{ V} + 0.25 \text{ V}) = 0.5 \text{ V} + 0.25 \text{ V} + 0.5 \text{ V} - 0.25 \text{ V} = 1 \text{ V}$$

6. Can **patch cables**, that are wired according to the **T568A** wiring standard, be used in an computer network infrastructure, which uses the the **T568B** wiring standard?

This is no problem because patch cables are always 1:1 wired. Patch cables do not have an effect on the internal wiring of the jacks.

7. Why is it impossible to **connect different buildings** with **shielded cables**?

Shields must be electrically grounded on both sides of the cable. If only one end of a shielded cable is grounded, an antenna effect occurs, which results in a compensation current.

8. Name a benefit and a drawback of **mono-mode (single-mode) fibers** compared with multi-mode fibers.

Advantage: Can be used for long distances (up to about 70 km).

Drawback: Only a single propagation mode.

9. Name a benefit and a drawback of **multi-mode fibers** compared with mono-mode (single-mode) fibers.

Advantage: Several thousand propagation modes.

Drawback: Can only be used for short distances (up to about 500 m).

Exercise 3 (Shielding of Twisted Pair Cables)

The following information come from existing twisted pair network cables. What information is provided about the **cable and pair shielding** of these cables?

1. E138922 RU AWM 2835 24 AWG 60°C CSA LL81295 FT2 ETL VERIFIED
EIA/TIA-568A CAT.5 UTP EVERNEW G3C511

UTP = Unshielded Twisted Pair

2. E188601 (UL) TYPE CM 75°C LL84201 CSA TYPE CMG FT4 CAT.5E PATCH
CABLE TO TIA/EIA 568A STP 26AWG STRANDED

STP = Shielded Twisted Pair

3. E324441 RU AWM 2835 24AWG 60°C 30V CHANGJIANG TIA/EIA 568B.2 UTP
CAT.5e

UTP = Unshielded Twisted Pair

4. SSTP ENHANCED CAT.5 350MHZ 26AWG X 4P PATCH TYPE CM (UL) C(UL)
E200579 CMG CSA LL81924 3P VERIFIED

SSTP = Screened Shielded Twisted Pair

5. EC-net 7.5 m 11184406 13/03 PremiumNet 4 PAIR 26AWG S-FTP HF IEC
332-1 ENHANCED CATEGORY 5 PATCH CORD EN0173+ISO/IEC

SFTP = Screened Foiled Twisted Pair

6. (UL) E228252 TYPE CM 75°C 24AWG 4PR UTP C(UL) E228252 CMR 73°C
ETL VERIFIED TIA/EIA 568B.2 CAT.5e

UTP = Unshielded Twisted Pair

Exercise 4 (Network Cables)

On network cables, strings of letters, numbers and special characters are printed. Their content is at first sight difficult to understand.

Example:

E188601 (UL) TYPE CM 75°C LL84201 CSA TYPE CMG FT4 CAT.5E PATCH CABLE
TO TIA/EIA 568A STP 26AWG STRANDED

1. What means STRANDED?

Stranded cables are typically used to create patch cables because they are very flexible.

2. Do cables exist which are not STRANDED?

Solid cables are less flexible than stranded cables and they are typically used for permanent installation (structured wiring in a building).

3. What is the meaning of PATCH?

Patch cables are used to connect network devices.

4. Do cables exist which are not PATCH?

Crossover cables exist.

5. What is the difference between PATCH cables and other cables?

Crossover cables are used to connect two network devices directly, without a Hub or Switch. A crossover cable contains crossing wires, which connect the output pins with the input pins of both devices.

6. What is the meaning of the information 24AWG or 26AWG?

American wire gauge (AWG) is a standardized wire gauge system, which is used mainly in the United States and Canada for the diameters of electrically conducting wires.

AWG-24 = 0.51054 mm diameter.

AWG-26 = 0.405 mm diameter.

7. What is the meaning of the information UL CM FT1/FT4 together with a degree value (e.g. 60°C or 75°C)?

FT1 and FT4 are vertical flame tests.

Exercise 5 (Repeaters and Hubs)

1. What is the purpose of **Repeaters** in computer networks?

A Repeater retransmits all received signals at a higher level or higher power, so that the signal can cover longer distances.

2. What is the major difference between **Repeaters** and **Hubs**?

Hubs are Repeaters with > 2 interfaces.

3. Why do Repeaters and Hubs not require **physical or logical addresses**?

Repeaters and Hubs have no physical or logical network addresses because they just forward the received signals.

4. What **network topology(s)** do Hubs implement?

Physical topology: Star network because of the cabling.

Logical topology: Bus network, because equal to a long cable, were all network devices are connected with, a Hub forwards incoming signals to all other interfaces.

5. Name two **advantages of using a Hub** compared to a physical Bus network.

Better reliability, because the failure of individual cable segments does not result in a complete network failure.

Adding or removing network devices does not cause network interruptions.

6. What is a **collision domain**?

The collision domain is a network or a section of a network where multiple network devices use a shared transmission medium. It includes all network devices which compete for accessing a shared transmission medium.

7. What says the **5-4-3 rule**?

In a collision domain, not more than 5 segments can be connected. For this, a maximum of 4 Repeaters are used. Only at 3 segments, active senders (terminal devices) can be connected.

8. Why does the **5-4-3 rule** exist?

Hubs cannot be cascaded infinitely. The round-trip time (RTT) must not be exceeded. If the network is too large, the RTT will become too high. Then collisions occur more frequent and undetected collisions are possible.

Exercise 6 (Line Codes)

1. Explain why computer networks require line codes.

Computers are digital machines. Transmission mediums work analogous. The line codes specify the conversion of binary data (\implies binary numbers) into signals (encoding).

2. Many different line codes exist. Explain why it is impossible to use one single line code for every network technology.

*Different transmission mediums are used for computer networks.
Different numbers of signal levels are used.*

3. Explain the way Non-Return-To-Zero (NRZ) works.

It represents logical 0 and 1 is by using different voltage levels.

4. Name the two problems that can occur when NRZ is used to encode data.

Baseline Wander and Clock Recovery.

5. Explain both problems from subtask 4 in detail.

Baseline Wander = shift of the average when using NRZ. The receiver distinguishes the physical signal levels by using the average of a certain number of received signals. Signals far below the average, interprets the receiver as logical 0 bit. Signals significantly above the average, interprets the receiver as logical 1 bit. When transmitting a long series of logical 0 bits or 1 bits, the average can shift so much, making it difficult to detect a significant change in the physical signal.

Clock Recovery when using NRZ. Even if the processes for encoding and decoding run on different computers, they need to be controlled by the same clock. In each clock cycle, the sender transmits a bit and the receiver receives a bit. If the clocks of sender and receiver drift apart, the receiver may lose count during a long sequence of logic 0 bits or 1 bits.

6. Explain how the problems from subtask 4 can be avoided.

In order to prevent Baseline Wander, when using a line code with 2 physical signal levels, the usage of both signal levels must be equally distributed.

One way to avoid the clock recovery problem is by using a separate line, which transmits just the clock. In computer networks, a separate signal line just for the clock is not practical because of the cabling effort. Instead, it is recommended to increase the number of guaranteed signal level changes to enable the clock recovery from the data stream.

7. Name at least 5 line codes that use 2 signals levels.

NRZ, NRZI, Unipolar RZ, Manchester, Manchester II, Differential Manchester.

8. Name at least 3 line codes that use 3 signal levels.

MLT-3, RZ, AMI, B8ZS.

9. Which line codes ensure a signal level change for each logical 1 bit?

NRZI, MLT-3, Unipolar RZ, AMI, B8ZS.

10. Which line codes ensure a signal level change for each transmitted bit?

RZ, Manchester, Manchester II, Differential Manchester.

11. Why do not all line codes ensure a signal level change for each transmitted bit?

Lack of efficiency.

12. Which line codes ensure that the signal levels are equally distributed?

AMI, B8ZS, Manchester, Manchester II.

13. Why is it important for the receiver of signals, which are encoded according to the Differential Manchester Encoding, to know the initial signal level?

Depending on the initial signal level, two signal sequences, inverse to each other, are possible.

14. What is a scrambler?

A scrambler is a device, which modifies a data stream according to a simple algorithm in a way that it is easy to reverse.

15. Why are scramblers used?

When the AMI line code is used, clock recovery is impossible for the receiver, when series of logical 0 bits are transmitted. In AMI case, scramblers are used, to interrupt long series of logic 0 bits. This makes the clock recovery for the receiver possible.

16. All line codes have drawbacks. What can be done to avoid the problems, that can result from these drawbacks?

Modern network technologies encode the bit stream first with a line code that works efficient on the one hand, but also ensures clock recovery and avoids baseline wander. These encodings improve the bit stream in a way, that a further encoding with the line codes NRZ, NRZI and MLT-3 does not result in any problems. Examples of line codes, which improve the bit stream first, are 4B5B, 5B6B and 8B10B. These line codes encode fixed-size input blocks into fixed-size output blocks.

17. Which line code maps groups of 4 payload bits onto groups of 5 code bits?

4B5B

18. Which line code maps groups of 5 payload bits onto groups of 6 code bits?

5B6B

19. Why do some line codes, that map groups of payload bits onto groups of code bits, implement variants with neutral inequality, positive inequality and negative inequality?

Variants with positive or negative inequality alternate to prevent Baseline Wander.

20. How is the efficiency of a line code calculated?

Efficiency = ratio of bit rate (payload in bits per time) and baud rate (signal changes per second).

Exercise 7 (Encoding Data with Line Codes)

1. Give the encodings for the given bit pattern.

Attention: Please assume that the initial signal level of NRZI and Differential Manchester Encoding is signal level 1 (low signal).

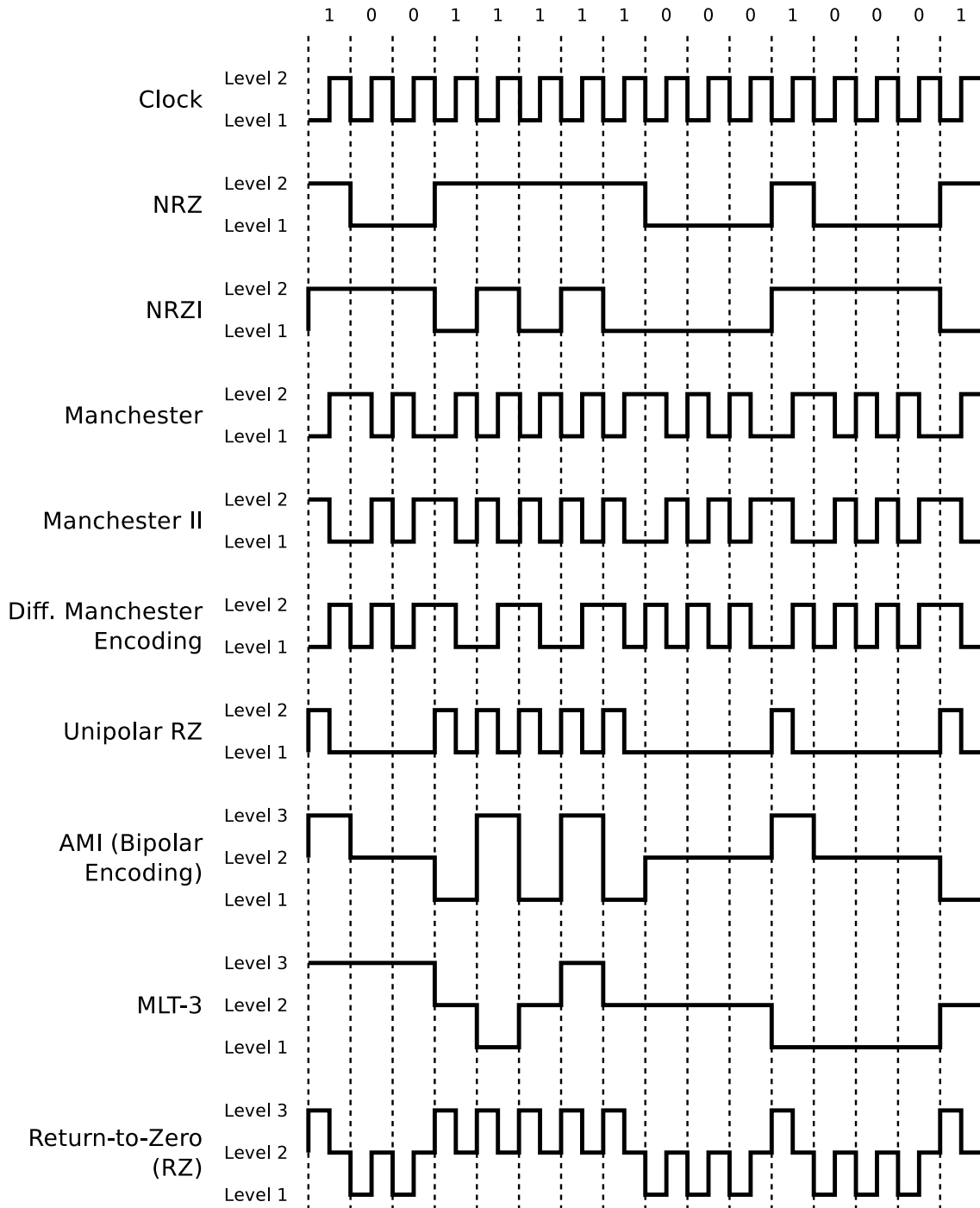

2. Encode the bit sequences with 4B5B and NRZI and draw the signal curve.

- 0010 1111 0001 1010
- 1101 0000 1001 1110

Attention: Please assume that the initial signal level of NRZI is signal level 1 (low signal).

Label	4B	5B	Function
0	0000	11110	0 hexadecimal
1	0001	01001	1 hexadecimal
2	0010	10100	2 hexadecimal
3	0011	10101	3 hexadecimal
4	0100	01010	4 hexadecimal
5	0101	01011	5 hexadecimal
6	0110	01110	6 hexadecimal
7	0111	01111	7 hexadecimal
8	1000	10010	8 hexadecimal
9	1001	10011	9 hexadecimal
A	1010	10110	A hexadecimal
B	1011	10111	B hexadecimal
C	1100	11010	C hexadecimal
D	1101	11011	D hexadecimal
E	1110	11100	E hexadecimal
F	1111	11101	F hexadecimal

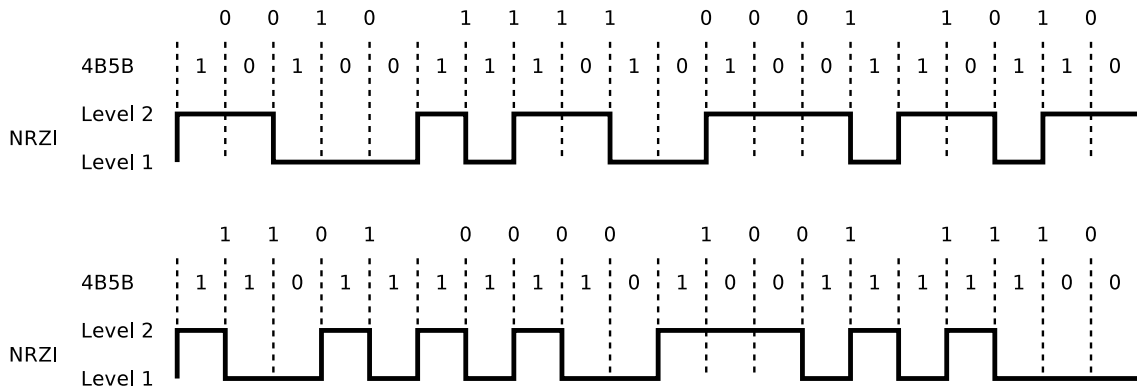

3. Encode the bit sequences with 5B6B and NRZ and draw the signal curve.

- 00001 01011 11000 01110 10011
- 11010 11110 01001 00010 01110

5B	6B neutral	6B positive	6B negative	5B	6B neutral	6B positive	6B negative
00000		001100	110011	10000		000101	111010
00001	101100			10001	100101		
00010		100010	101110	10010		001001	110110
00011	001101			10011	010110		
00100		001010	110101	10100	111000		
00101	010101			10101		011000	100111
00110	001110			10110	011001		
00111	001011			10111		100001	011110
01000	000111			11000	110001		
01001	100011			11001	101010		
01010	100110			11010		010100	101011
01011		000110	111001	11011	110100		
01100		101000	010111	11100	011100		
01101	011010			11101	010011		
01110		100100	011011	11110		010010	101101
01111	101001			11111	110010		

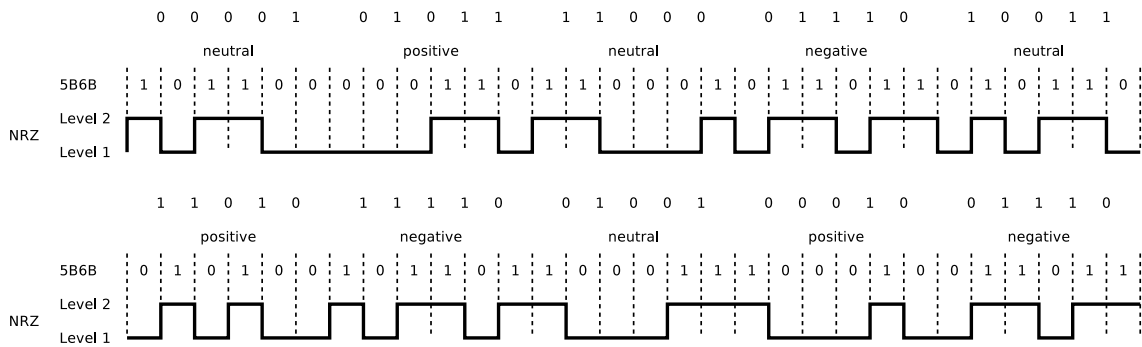

4. These signal curves are encoded with NRZI and 4B5B. Decode the data.

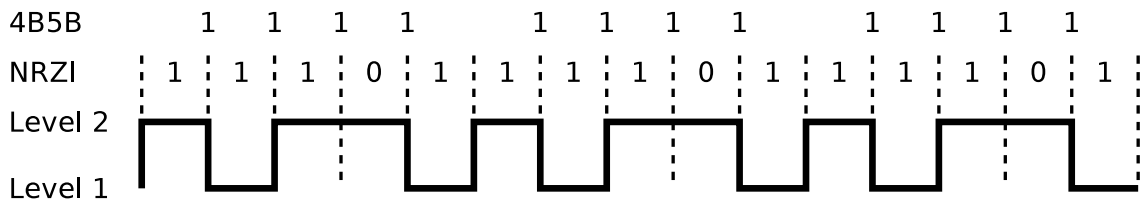
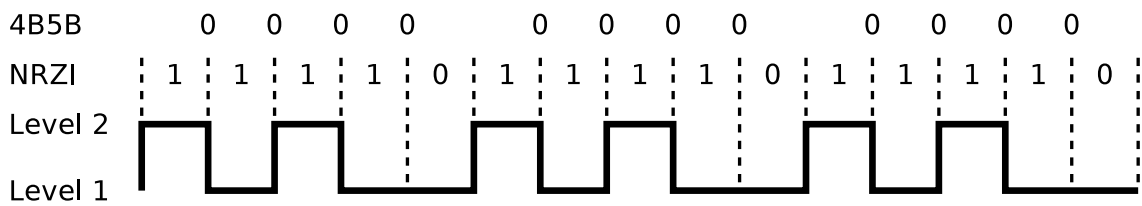
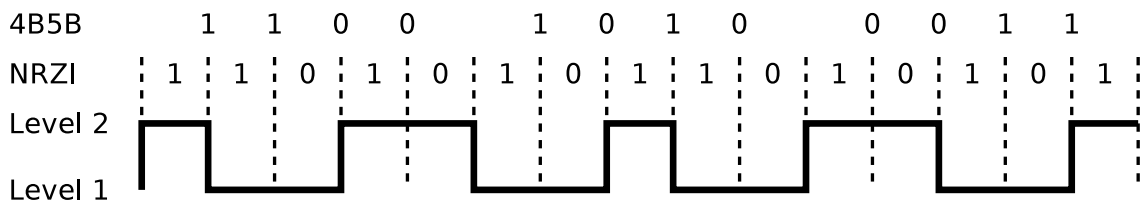

Source: Jörg Roth. Prüfungstrainer Rechnernetze. Vieweg (2010)