

Introduction and Fundamentals

Practical Computer Networks and Applications

Prof. Dr. Christian Baun

Frankfurt University of Applied Sciences
(1971–2014: Fachhochschule Frankfurt am Main)
Faculty of Computer Science and Engineering
christianbaun@fb2.fra-uas.de

v1.3 (11th May 2023)

Contents

- 1 Introduction
- 2 Fundamentals
- 3 Physical Layer
- 4 Data Link Layer
- 5 Network Layer
- 6 Transport Layer
- 7 Application Layer

Introduction to PCNA

The course **Practical Computer Networks and Applications** consists of two parts:

- 1 The theoretical lecture on computer networks
- 2 The practical lab exercises on the application of computer networks

Theoretical lecture

This slide set is a summary of the fundamental theoretical knowledge of the course **Computer Networks** from the winter term! It is intended to remind you of the topics discussed last semester and will give you a brief summary of the protocols and technologies necessary for this course!

The theoretical foundation for this course

- The Lab Exercise will use technologies from all network layers and therefore the knowledge on the technologies and protocols is necessary for the successful participation in the lab!
- You can use this slide set as a tool for the lab exercises!
- Each lab exercise will be accompanied by a corresponding slide set!

The Foundation

This slide set will give you fundamental theoretical knowledge of the lab exercises. The practical exercises will demonstrate their use in practice!

Organizational Information

- **E-Mail:** christianbaun@fb2.fra-uas.de

!!! Tell me when problems exist at an early stage !!!

- **Homepage:**

https://www.christianbaun.de/CompNetLab23/index_en.html

- The homepage contains among others
 - **Schedule of the Course and Presentation slides**

!!! Check the course page regularly !!!

You need to register here

<https://campuas.frankfurt-university.de/course/view.php?id=3665>

You need to upload your submissions here

<https://campuas.frankfurt-university.de/course/view.php?id=1601>

Literature

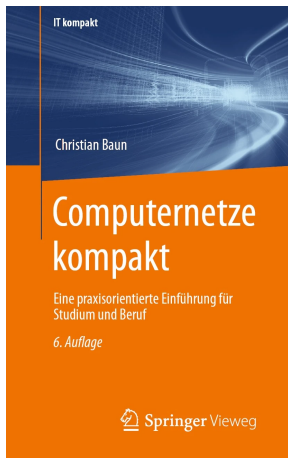
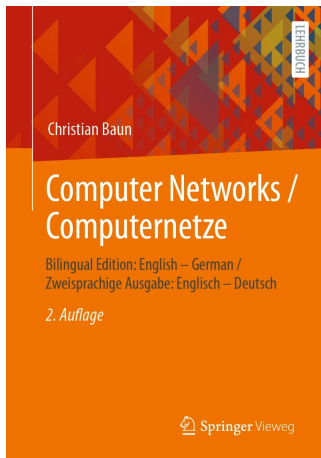

- My slide sets were the basis for these books
- The two-column layout (English/German) of the bilingual book is quite useful for this course

You can download both books for free via the FRA-UAS library from the intranet

Learning Objectives of this Slide Set

- Organizational Information
- Fundamentals of computer networks
 - Network services
 - Transmission media
 - Network protocols

This slide set includes the topics of the hybrid reference model layers that are most relevant for this course

Contents

- 1 Introduction
- 2 Fundamentals**
- 3 Physical Layer
- 4 Data Link Layer
- 5 Network Layer
- 6 Transport Layer
- 7 Application Layer

Some questions. . . (1)

• Serial vs. parallel data transmission

- Explain the difference.
- Name an advantage of serial data transmission.
- Name an advantage of parallel data transmission.
- Computer networks usually implement: serial parallel

• Network topologies

- Explain what the physical topology of a computer network describes.
- Enumerate what the logical topology of a computer network describes.
- Modern Ethernets implement: Bus Star Tree Mesh Ring

• Directional dependence

- Explain what simplex, full-duplex, and half-duplex means.
- Ethernet operates in: simplex full-duplex half-duplex
- WiFi with an AP operates in: simplex full-duplex half-duplex
- Explain why not all computer networks do operate in full-duplex mode.

Protocols

- A **protocol** is the set of all previously made **agreements** between communication partners
 - These agreements include:
 - Rules for connection establishment and clearing
 - Method of synchronization between sender and receiver
 - Measures for the detection and treatment of transmission errors
 - Definition of valid messages (vocabulary)
 - Format and encoding of messages
- Protocols specify...
 - the **syntax** (= format of valid messages)
 - the **semantics** (= vocabulary and meaning of valid messages)

Reference Models

- Communication in computer networks is subdivided into **reference models**
- Each **layer** of a reference model handles a particular aspect of communication and offers **interfaces** to the overlying layer and underlying layer
- Each interface consists of a set of **operations**, which together define a **service**
- In the layers, the data is encapsulated (\implies **encapsulation**)
- Because each layer is complete in itself, single protocols can be modified or replaced without affecting all aspects of communication
- The most popular reference models are...
 - the **TCP/IP reference model**,
 - the **OSI reference model**
 - and the **hybrid reference model**

TCP/IP Reference Model or DoD Model

- Developed from 1970 onwards by the Department of Defense (DoD) in the Arpanet project
- Divides the required functionality to realize communication into 4 layers
- For each layer, it is specified, what functionality it provides
 - These requirements are implemented by communication protocols
 - Concrete implementation is not specified and can be implemented in different ways
 - Therefore, for each of the 4 layers, multiple protocols exist

Number	Layer	Protocols (Examples)
4	Application Layer	HTTP, FTP, SMTP, POP3, DNS, SSH, Telnet
3	Transport Layer	TCP, UDP
2	Internet Layer	IP (IPv4, IPv6), ICMP, IPsec, IPX
1	Link Layer	Ethernet, WLAN, ATM, FDDI, PPP, Token Ring

TCP/IP Reference Model – Message Structure

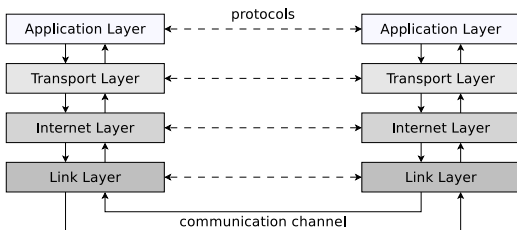

- Each layer adds additional information as **header** to the message
 - Some protocols (e.g. Ethernet) add in the link layer not only a header but also a **trailer** at the end of the message
 - The receiver analyzes the header (and trailer) on the same layer

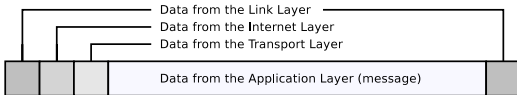

Hybrid Reference Model

- The TCP/IP reference model is often presented in the literature (e.g. by Andrew S. Tanenbaum) as a 5-layer model
 - Reason: It makes sense to split the **Link Layer** into 2 layers, because they have different tasks
- This model is an extension of the TCP/IP model and is called **hybrid reference model**

TCP/IP Reference Model

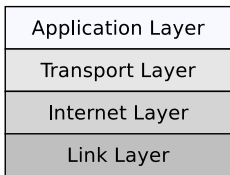

Hybrid Reference Model

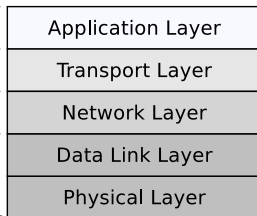

The objects of the individual layers will be discussed on the basis of the hybrid reference model

Physical Layer

- **Transmits the ones and zeros**
 - **Physical connection** to the network
 - **Conversion of data in signals**
- Protocol and transmission medium specify among others:
 - How many bits can be transmitted per second?
 - Can transmission take place simultaneously in both directions?
- Devices: **Repeater**, **Hub** (Multiport Repeater)

Hybrid Reference Model

Application Layer
Transport Layer
Network Layer
Data Link Layer
Physical Layer



Data Link Layer

- Ensures error-free data exchange of **frames** between devices in physical networks
 - Detects transmission errors with **checksums**
 - Controls the access to the transmission medium (e.g. via CSMA/CD or CSMA/CA)
- Specifies physical network addresses (**MAC addresses**)
- At sender site: Packs the Network Layer packets into frames and transmits them (in a reliable way) via a physical network from one device to another
- At receiver site: Identifies frames in the bit stream from the Physical Layer
- Devices: **Bridges, Layer-2-Switches** (Multiport Bridges) and **Modems** connect physical networks

Hybrid Reference Model

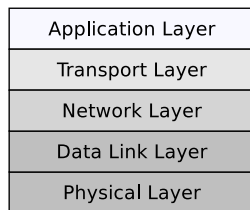

Network Layer

- Forwards (*routes*) **packets** between logical networks (over physical networks)
 - For this *internetworking*, the Network Layer defines **logical addresses (IP addresses)**
 - Each IP packet is *routed* independently to its destination and the path is not recorded
- At sender site: Packs the segments of the Transport Layer in packets
- At receiver site: Unpacks the packets in the frames from the Data Link Layer
- **Routers** and **Layer-3-Switches** connect logical networks
- Usually the connectionless Internet Protocol (IP) is used
 - Other protocols (e.g. IPX) have been replaced by IP

Hybrid Reference Model

Application Layer
Transport Layer
Network Layer
Data Link Layer
Physical Layer



Transport Layer

- Transports **segments** between processes on different devices via so-called end-to-end protocols
- At sender site: Packs the data of the Application Layer into segments
- At receiver site: Unpacks the segments inside the packets from the Network Layer
- Addresses processes with **port numbers**
 - Data Link Layer and Network Layer implement physical and logical addressing of the network devices
- Transport protocols implement different forms of communication
 - UDP (User Datagram Protocol): Connectionless communication
 - TCP (Transport Control Protocol): Connection-oriented communication
 - Combination of TCP/IP = de facto standard for computer networks

Hybrid Reference Model

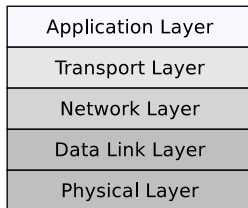

Application Layer

- Contains all protocols, that interact with the application programs (e.g. browser or email program)
- Here are the messages (e.g. HTML pages or emails), formatted according to the used application protocol
- Some Application Layer protocols: HTTP, FTP, SMTP, POP3, DNS, SSH, Telnet

Hybrid Reference Model

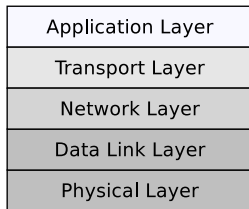

wikipedia.org (CC0)



pixabay.com (CC0)

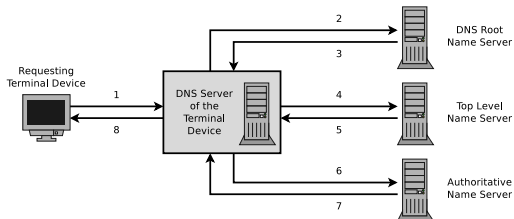

How Communication works (1/2)

• Vertical communication

- Messages are packed from top to bottom layer by layer and extracted at the receiver in the reverse layer sequence
- **Data encapsulation and de-encapsulation**

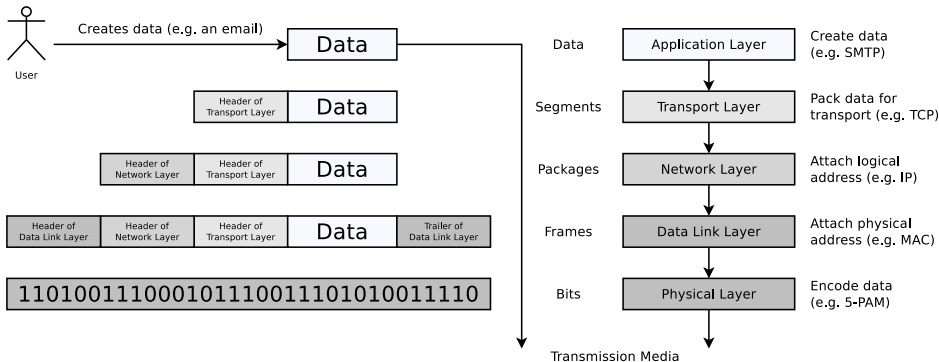

How Communication works (2/2)

• Horizontal communication

- Equal protocol functions are used in the equivalent layers by sender and receiver

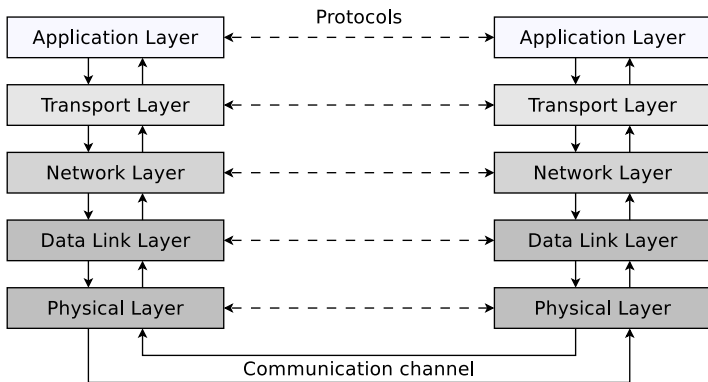

OSI Reference Model

- Some years after the TCP/IP reference model (1970s), the OSI reference model was developed from 1979 onwards
 - 1983: Standardized by the Intern. Organization for Standardization (ISO)
 - OSI = Open Systems Interconnection
- The structure is similar to the TCP/IP reference model
 - The OSI model implements 7 layers
- In contrast to the hybrid reference model, the Application Layer functionality is distributed across 3 layers in the OSI reference model

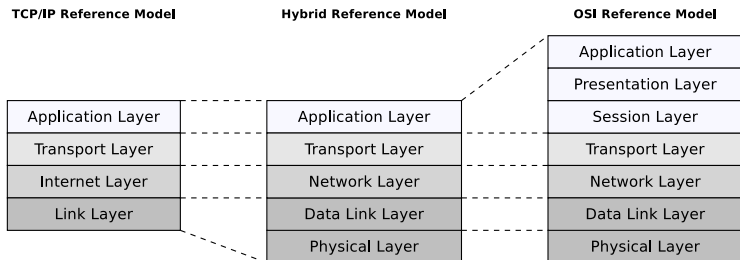

Some questions. . . (2)

- Give the number of Bits, a Gigabit contains.
- Give the number of Bits, a Gigabyte contains.
- **Transfer time (latency)**
 - Explain what latency in a computer network describes.
 - Explain why the Signal propagation speed is limited.
 - Explain how latency is calculated.
 - Explain what the Bandwidth-Delay Product is.
- **Reference models layers**
 - Explain why the Presentation and Session Layer are not used in practice.
 - Name the layers that specify frames, packets, segments, and signals.
 - Name the layers that specify addresses.
 - Give the technical terms of the addresses.
 - Explain what exactly (components/devices/software) is addressed in the single layers.
 - Assign Bridge, Gateway, Router, Repeater, Switch, and Workstation to the single layers.
 - Name the reference model that is most close to practice.

Contents

- 1 Introduction
- 2 Fundamentals
- 3 Physical Layer**
- 4 Data Link Layer
- 5 Network Layer
- 6 Transport Layer
- 7 Application Layer

Ethernet (IEEE 802.3)

- The most frequently used (cable-based) LAN technology since the 1990s
- Several Ethernet standards exist

Standard	Mbps	Transmission Medium
10BASE2/5	10	Coaxial cables (50 ohm impedance)
10BROAD36	10	Coaxial cables (75 ohm impedance)
10BASE-F	10	Fiber-optic cables
10BASE-T	10	Twisted pair cables
100BASE-FX	100	Fiber-optic cables
100BASE-T4	100	Twisted pair cables (Cat 3)
100BASE-TX	100	Twisted pair cables (Cat 5)
1000BASE-LX	1.000	Fiber-optic cables
1000BASE-SX	1.000	Fiber-optic cables (Multi-mode fiber)
1000BASE-ZX	1.000	Fiber-optic cables (Single-mode fiber)
1000BASE-T	1.000	Twisted pair cables (Cat 5)
1000BASE-TX	1.000	Twisted pair cables (Cat 6)
2.5GBASE-T	2.500	Twisted pair cables (Cat 5e)
5GBASE-T	5.000	Twisted pair cables (Cat 6)
10GBASE-SR	10.000	Fiber-optic cables (Multi-mode fiber)
10GBASE-LR	10.000	Fiber-optic cables (Single-mode fiber)
10GBASE-T	10.000	Twisted pair cables (Cat 6A)
40GBASE-T	40.000	Twisted pair cables (Cat 8.1)

- 2 different transmission modes exist:

- 1 **Baseband (BASE)**
- 2 **Broadband (BROAD)**

Naming convention

- Part 1: Data rate
- Part 2: Transmission method (baseband or broadband)
- Part 3: 100 times the maximum segment length or the transmission medium

10BASE5 for example means...

- Data rate: 10 Mbps
- Transmission method: Baseband
- Maximum segment length: $5 * 100\text{m} = 500\text{m}$

Variants of Ethernet – Baseband (BASE)

- Almost all Ethernet standards implement the baseband transmission method (BASE)
 - Single exception: 10BROAD36
- Baseband systems have **no carrier frequencies**
 - This means that **data is directly (at baseband) transmitted on the transmission medium**
- Digital signals are injected directly as impulses into the copper cable or fiber-optic and occupy the entire bandwidth of the cable or a part of it
 - Unused bandwidth can not be used for other services

In short...

Baseband systems provide just a **single channel**

We can ignore Broadband in this course

Twisted Pair Cables

- Since the 1990s, twisted-pair cables and RJ45 plugs and jacks are **standard for copper-based IT networking**
- The wires of twisted-pair cables are pairwise twisted with each other
- Twisted pairs are better protected against alternating magnetic fields and electrostatic interferences from the outside than parallel signal wires
- All variants of the Ethernet standard, that use twisted pair cables as transmission medium, use plugs and jacks according to the standard 8P8C, which are usually called RJ45

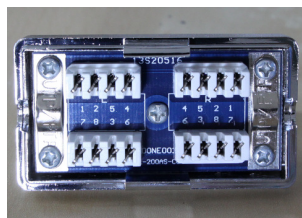
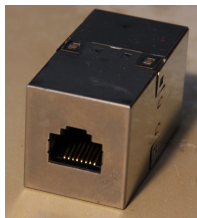
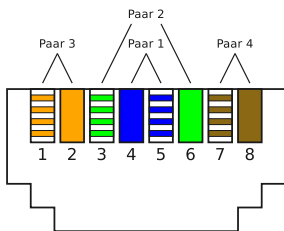
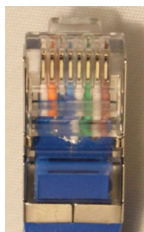

Wiring

- T568A and T568B are standards for the pin assignment of the RJ45 plugs and jacks and are used for Fast Ethernet 100BASE-TX and Gigabit Ethernet 1000BASE-T
 - Difference: The wire pairs 2 and 3 (green and orange) are interchanged
 - Mixing T568A and T568B in a computer network is a bad idea

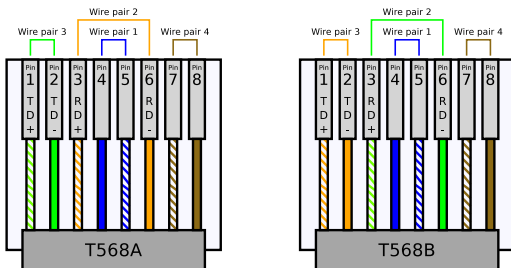

This is T568B

When using 10BASE-T, 4 PINs are used – The remaining wire pairs are not used

- Ethernet 10BASE-T and Fast Ethernet 100BASE-TX both only use 2 pairs of wires for sending and receiving
- TD+ and TD- (Trancieve Data) is the wire pair for data output signal
- RD+ and RD- (Recieve data) is the wire pair for data input
- Fast Ethernet 100BASE-T4 and Gigabit Ethernet 1000BASE-T both use all 4 pairs of wires for sending and receiving

Twisted Pair Cables – Examples

Image Source: (Kabel): Wikipedia (CC0)

- A metal shield reduces electromagnetic interferences

Example 1: UTP

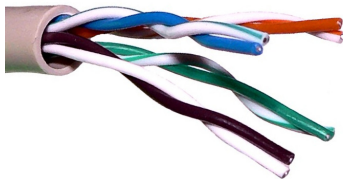

Example 2: FUTP = FTP

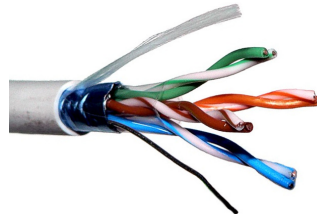

Example 3: SFTP

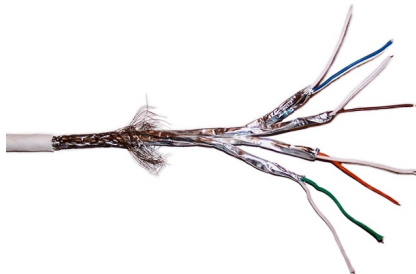

Structure (SFTP)

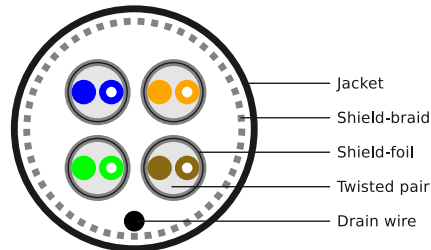

Categories of Twisted Pair Cables (1/3)

- Different categories of twisted pair cables exist
- The performance of a network connection is determined by the component of the lowest category
 - Example: Devices, which support Cat6, are connected via a Cat5 cable
 - This reduces the performance of the connection to the values of Cat5
- **Category 1/2/3/4**
 - Not common today (except for telephone cables)
- **Category 5/5e**
 - Cat5e is guaranteed Gigabit Ethernet-compatible
 - It meets stricter test standards than Cat5 cables
 - Common in most current LANs

Category	Max. frequency	Compatible with. . .
Cat-5	100 MHz	100BASE-TX (100 Mbps, 2 wire pairs, 100 m) 1000BASE-T (1 Gbps, 4 wire pairs, 100 m)
Cat-5e	100 MHz	2.5GBASE-T (2.5 Gbps, 4 wire pairs, 100 m)

Categories of Twisted Pair Cables (2/3)

Image Source: Reddit

• Category 6/6A

Category	Max. frequency	Compatible with...
Cat-6	250 MHz	5GBASE-T (5 Gbps, 4 wire pairs, 100 m) 10GBASE-T (10 Gbps, 4 wire pairs, 55 m)
Cat-6A	500 MHz	10GBASE-T (10 Gbps, 4 wire pairs, 100 m)

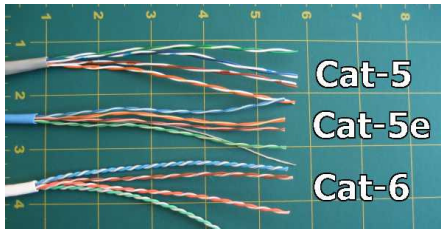
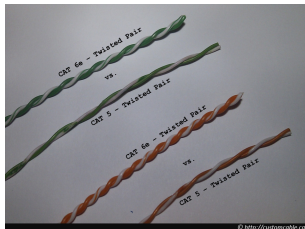

Main differences (of the structure) between the categories: number of twists per wire length (cm) and thickness of the jacket

- More twists per cm \implies less interference (noise)
- Cat 5/5e has 1-2 twists per cm. Cat 6 has 2 or more twists per cm
- Thickness of the cladding \implies less crosstalk
- Crosstalk is the mutual interference of parallel lines

Categories of Twisted Pair Cables (3/3)

• Category 7/7A

- For Cat 7 and Cat 7A cables, other connectors (e.g., TERA or GG45) and sockets than RJ45 were initially intended
 - However, these connectors were not successful in the market
 - **Cat 7 and 7A cabling with RJ45 connectors offers no benefits over category 6A cables**

Category	Max. frequency	Compatible with. . .
Cat-7	600 MHz	10GBASE-T (10 Gbps, 4 wire pairs, 100 m)
Cat-7A	1000 MHz	10GBASE-T (10 Gbps, 4 wire pairs, 100 m)

• Category 8.1

- This standard supports cables of up to 30 m in length
- Cables of this length are mostly sufficient for data centers

Category	Max. frequency	Compatible with. . .
Cat-8.1	2000 MHz	40GBASE-T (40 Gbps, 4 wire pairs, 30 m)

Information printed on Twisted Pair Cables (1/2)

Do you understand the most important cable characteristics that are printed on twisted pair cables?

Example: E188601 (UL) TYPE CM 75°C LL84201 CSA TYPE CMG FT4 CAT.5E PATCH CABLE TO TIA/EIA 568A STP 26AWG STRANDED

- **PATCH/CROSS/CROSSOVER:** Crossover or patch cable
- **UTP/STP/FTP/SFTP:** Shielding
- **CAT5/5E/6/7/8:** Category (see slides 30-32)
- **24AWG/26AWG/28AWG:** American wire gauge (AWG) informs about the diameters of the wires
 - 24AWG = 0.51054 mm, 26AWG = 0.405 mm, 28AWG = 0.321 mm
 - Larger wire diameter \implies less electrical resistance for the electronic signals \implies lower attenuation
 - 24AWG cables have lower attenuation than 26AWG or 28AWG cables
 - 28AWG cables are thinner than 24AWG or 26AWG
 - Thinner cables block airflow in server racks less and simplify the installation

Information printed on Twisted Pair Cables (2/2)

Do you understand the most important cable characteristics that are printed on twisted pair cables?

Example: E188601 (UL) TYPE CM 75°C LL84201 CSA TYPE CMG FT4 CAT.5E PATCH CABLE TO TIA/EIA 568A STP 26AWG STRANDED

- **60°C/75°C**: Temperature information stands for flame tests
- **SOLID/STRANDED**
 - **Solid** cables use solid copper wires. Such cables are well suited for permanent infrastructure installation. They have a lower attenuation and cost less compared to stranded cables
 - **Stranded** cables consist of multiple strands of wires wrapped around each other. They are typically used to create patch cables because they are very flexible. Attenuation of stranded cables is higher compared to solid cables. Thus, they are used for shorter distances

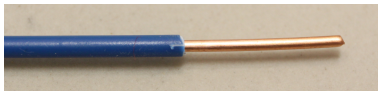

Left image: Solid cable

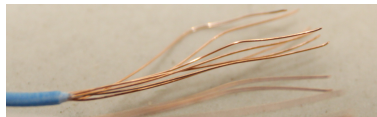

Right image: Stranded cable

Some questions. . . (3)

- Name a modern network technology that implements. . .
 - implements the baseband transmission method.
 - implements the broadband transmission method.
- Twisted-pair cables
 - Explain why the wires in twisted-pair cables are pairwise twisted with each other.
 - Explain why Ethernet transfers via every wire pair the signal and a complementary signal both.
 - Explain what crossover cables are.
 - Give a scenario where such cables were useful.
 - Explain why crossover cables are not relevant in practice any longer.
 - Explain what happens when using crossover cables with modern Ethernet components.
 - Is it possible to use shielded cables in every scenario? Explain your answer.
 - Give the characteristics of a twisted-pair cable. . .
 - that you install in a wall.
 - that you use to connect your network devices.
 - that you use to connect different buildings.

Contents

- 1 Introduction
- 2 Fundamentals
- 3 Physical Layer
- 4 Data Link Layer**
- 5 Network Layer
- 6 Transport Layer
- 7 Application Layer

Devices of the Data Link Layer: Bridges

- Devices of the Physical Layer increase the length of physical networks
 - For connecting different physical networks, **Bridges** are required because they forward frames from one physical network to another one
- A Bridge has only 2 ports
 - Such bridges usually connect networks based on different technologies (transmission media)
- Simple Bridges forward all incoming frames



- Bridges with > 2 ports are called **Multiport Bridge** or **Layer-2-Switch**
 - They typically provide 4-48 interfaces

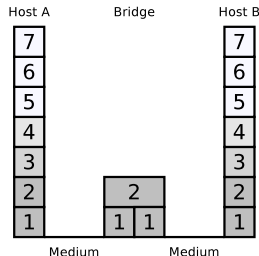

Functioning of Bridges and Layer-2-Switches

- Bridges and Switches check the correctness of the frames via **checksums**
- Bridges do **not need addresses** for filtering and forwarding the frames, because they do not actively participate in the communication
 - They operate transparent, just like the devices of the Physical Layer
 - Reason: They do not communicate on a higher protocol layer as the Data Link Layer

Collision Domain – Bridges and Layer-2-Switches

- Bridges and Switches operate on Data Link Layer and forward frames from one physical network to other ones
- **Each physical network is a separate collision domain**
 - If a physical network is split by a Bridge or a Switch, also the collision domain is split
 - As effect, the number of collisions drops
- For Bridges and Switches, each port forms its own collision domain

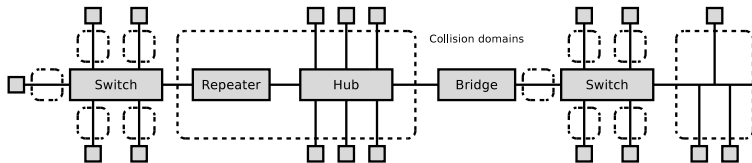

- In a **fully switched network**, each port of the Switches is connected with just a single network device
 - Such a network is collision-free and state of the art

Addressing in the Data Link Layer

- The Data Link Layer protocols specify the format of the physical network addresses
- **Terminal devices (Hosts), Routers and Layer-3-Switches** require physical network addresses
 - Such devices must be addressable on Data Link Layer because they provide services at upper protocol layers
- **Bridges and Layer-2-Switches** do not actively participate in the communication
 - Therefore, they don't require physical network addresses for their basic functionality, which is the filtering and forwarding of frames
 - Bridges and Switches require physical network addresses, when they implement the STP to avoid loops, or when they offer services from an upper protocol layer
 - Examples are monitoring services or graphical web interfaces for administration tasks
- **Repeaters and Hubs** that operate only at the Physical Layer, have no addresses

MAC Addresses (1/2)

- The **physical network addresses** are called **MAC addresses** (Media Access Control)
 - They are independent from the logical addresses of the Network Layer
- Ethernet uses the **Address Resolution Protocol** (ARP) to resolute the logical addresses of the Network Layer (IPv4 addresses) to MAC addresses
 - For IPv6, the **Neighbor Discovery Protocol** (NDP) provides the identical functionality and operates in a similar way
- MAC addresses have a length of 48 bits (6 bytes)
 - Thus, the address space contains 2^{48} possible addresses
- In order to make the representation compact and human-friendly to read, MAC addresses are usually written in hexadecimal notation
 - The bytes are separated from each other with dashes (-) or colons (:)
- Example of the notation: 00-16-41-52-DF-D7

MAC Addresses (2/2)

- Each MAC address is intended to be permanently assigned to a network device and unique
 - But it is often possible to modify MAC addresses by software
 - However, this modification applies only until the next reboot of the computer
- **MAC broadcast address**
 - If a network device wants to send a frame to all other devices in the same physical network, it inserts MAC broadcast address in the destination address field of the frame
 - All 48 bits of this MAC address have the value 1
 - Hexadecimal notation: FF-FF-FF-FF-FF-FF
 - Bridges and Switches do not forward frames to other physical networks, that contain the MAC broadcast address in the destination address field

Uniqueness of MAC Addresses

- The first 24 bits of the MAC address space are managed by the Institute of Electrical and Electronics Engineers (IEEE)
 - These 24 bits long addresses are called **MA-L** (MAC Address Block Large) or **OUI** (Organizationally Unique Identifier)
 - The OUIs can be checked in this IEEE database:
<http://standards.ieee.org/develop/regauth/oui/public.html>
- The remaining 24 bits are specified by the hardware vendors independently for their network devices
 - That address space allows $2^{24} = 16,777,216$ individual device addresses per OUI

MAC addresses	Manufacturer	MAC addresses	Manufacturer	MAC addresses	Manufacturer
00-20-AF-xx-xx-xx	3COM	00-03-93-xx-xx-xx	Apple	00-0C-6E-xx-xx-xx	Asus
00-00-0C-xx-xx-xx	Cisco	00-50-8B-xx-xx-xx	Compaq	08-00-2B-xx-xx-xx	DEC
00-01-E6-xx-xx-xx	Hewlett-Packard	00-02-55-xx-xx-xx	IBM	00-02-B3-xx-xx-xx	Intel
00-04-5A-xx-xx-xx	Linksys	00-09-5B-xx-xx-xx	Netgear	00-04-E2-xx-xx-xx	SMC

- Smaller address spaces are available too: **MA-S** (MAC Address Block Small) and **MA-M** (MAC Address Block Medium)

Security Aspects of MAC Addresses

- For WLAN, MAC filters are often used to protect the Access Point
 - In principle, this makes sense, because the MAC address is the unique identifier of a network device
- However, the security level of MAC filters is low because MAC addresses can be modified via software
 - The method is called **MAC spoofing**

Working with MAC addresses under Linux

- Read out the own MAC address(es): `ip link` or `ifconfig`
- Read out the MAC address(es) of the neighbors (mostly the Routers): `ip neigh`
- Set MAC address: `ip link set dev <Interface> address <MAC Address>`
- Alternative: `ifconfig <Interface> promisc`
and next: `ifconfig <Interface> hw ether <MAC Address>`

Framing in current Computer Networks (2/4) – Ethernet

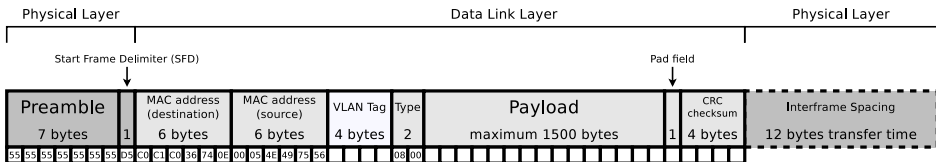

- The fields for the physical addresses (MAC addresses) of sender and destination are 6 bytes long each
- The 4 bytes long optional VLAN tag contains, among others...
 - a 12 bits long VLAN ID
 - and a 3 bits long field for the priority information
- The field Type contains the information what protocol is used in the next upper protocol layer

- If IPv4 is used, the field Type has value 0x0800
- If IPv6 is used, the field Type has value 0x86DD
- If the payload contains an ARP message, the field Type has value 0x0806

Framing in current Computer Networks (3/4) – Ethernet

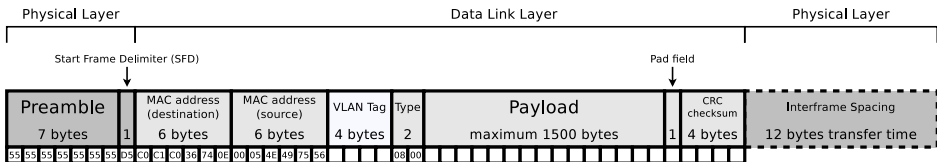

- Minimum size of an Ethernet frame: 72 bytes
- Maximum size (including preamble and SFD): 1526 bytes
- The VLAN tag increases the maximum size by 4 bytes
- Each frame can contain a maximum of 1500 bytes payload
 - With the Pad field, the frame length can be increased to the minimum frame size (72 bytes) when needed
 - This is required to get the collision detection via CSMA/CD working (⇒ slide set 6)
- The last field contains a checksum (32 bits) for all fields, except the preamble and SFD

Framing in current Computer Networks (4/4) – Ethernet

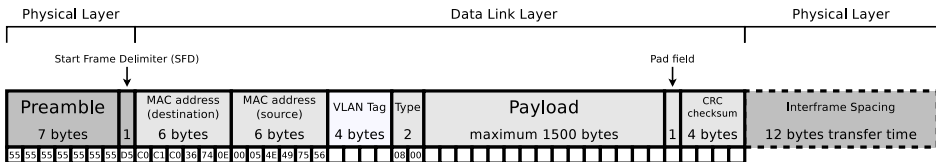

- The **Interframe Spacing** or **Interframe Gap** is the minimum idle period between the transmission of Ethernet frames via the transmission medium
- The minimum idle period is 96 bit times (12 bytes)
 - It is 9.6 microseconds when using 10 Mbps Ethernet
 - It is 0.96 microseconds when using 100 Mbps Ethernet
 - It is 96 nanoseconds when using 1 Gbps Ethernet
- Some network devices allow to reduce the Interframe Spacing period
 - Benefit: Better data rate is possible
 - Drawback: For the receiver it may become impossible to detect the frames' borders (\implies the number of collisions may rise)

Functioning of ARP (1/2)

- The **Address Resolution Protocol** (ARP) is used to resolve IP addresses of the Network Layer to MAC addresses of the Data Link Layer
- If a network device wants to transmit data to a receiver, it uses the receiver's IP address on the Network Layer
- But on the Data Link Layer, the MAC address is required
 - Therefore, **address resolution** must be carried out in the Data Link Layer
 - To find out the MAC address of a network device in the LAN, ARP sends a frame with the MAC broadcast address FF-FF-FF-FF-FF-FF as destination address
 - Each network device in the LAN receives and analyzes this frame
 - The frame contains the IP address of the searched network device
 - If a network device has this IP address, it sends an ARP response to the sender
 - The reported MAC address stores the sender in its local ARP cache

Functioning of ARP (2/2)

- The **ARP cache** is used to speed up the address resolution
 - It contains a table with these information for each entry:
 - Protocol type (IP)
 - Protocol address of the sender (IP address)
 - Hardware address of the sender (MAC address)
 - Time To Live (TTL)
 - The TTL is set by the operating system
 - If an entry in the table is used, the TTL is extended
- Modern Linux distributions discard entries after ≈ 5 minutes

The ARP cache can be displayed via `arp -n` or `ip neighbour`

```
# arp -n
Address          HWtype HWaddress          Flags Mask          Iface
192.168.178.1    ether  9c:c7:a6:b9:32:aa  C                wlan0
192.168.178.24   ether  d4:85:64:3b:9f:65  C                wlan0
192.168.178.41   ether  ec:1f:72:70:08:25  C                wlan0
192.168.178.25   ether  cc:3a:61:d3:b3:bc  C                wlan0
```

Address resolution requests can be send manually via `arping`

Structure of ARP Messages

- ARP messages are transmitted as payload via Ethernet frames
 - type = 0x0806 (for the ARP protocol)

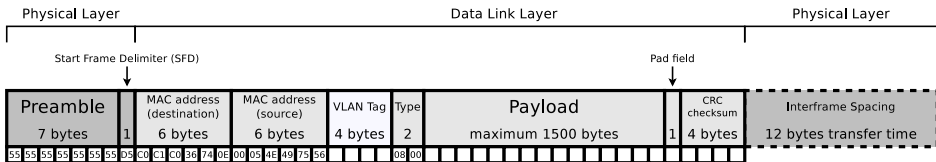

- HLEN = hardware address (MAC address) length in bytes
 - For Ethernet: 6 bytes
- PLEN = IP address length in bytes
 - For IPv4: 4 bytes

In an ARP request is the content of the field
MAC address (target) irrelevant

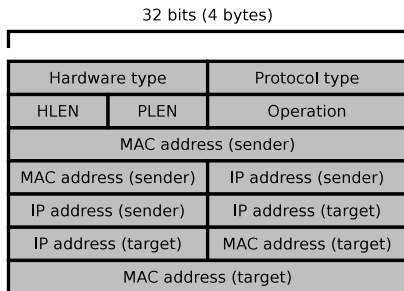

Some questions. . . (4)

• Devices of Data Link Layer

- Explain the purpose of Bridges and L2-Switches in computer networks.
- Explain why Bridges and L2-Switches do not require addresses.
- Explain the consequence of loops on Data Link Layer.
- Name the protocol that can handle loops on Data Link Layer.
- Explain the impact of Bridges and L2-Switches on the collision domain.
- Explain the benefit of a switched vs. a non-switched network.

• Addressing in the Data Link Layer

- Name the addresses the Data Link Layer protocols specify.
- Give the length (number of bytes) of these addresses.
- Specify what these addresses actually address.
- Explain if these addresses can be modified by the users.
- Communication partners in computer networks need to know their Data Link Layer addresses. Explain how Data Link Layer addresses can be obtained.

• Ethernet frames

- Name some information, the header of an Ethernet frame includes.
- Name the information, the trailer of an Ethernet frame includes.

Contents

- 1 Introduction
- 2 Fundamentals
- 3 Physical Layer
- 4 Data Link Layer
- 5 Network Layer**
- 6 Transport Layer
- 7 Application Layer

Router, Layer-3-Switch and Gateway

- **Routers** forward packets between networks with different logical address ranges
 - Provide exactly like Hubs and Switches multiple interfaces
 - Enable to connect the local network (LAN) with a WAN (e.g. via DSL or 3G/4G mobile network)
- **Layer-3-Switches** are Routers without a WAN interface
- **Gateways** are protocol converters
 - Enable communication between networks, which base on different protocols
 - A Gateway can in theory operate on all layers
 - Gateways, which operate on the Network Layer, are also called **Multiprotocol Routers**

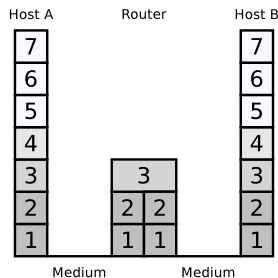

The two pictures below show a Linksys WRT54GL Wireless-G Wireless Router with a WAN port and a 4-port switch

Gateways

- Modern computer networks operate almost exclusively with the Internet Protocol (IP)
 - For this reason, a protocol conversion on the Network Layer is mostly not necessary
- In the past, in the network preferences of a terminal device, the IP address of the Gateway was specified as **Default Gateway**
 - Today, this field contains the Router address, because a Gateway is usually not required any longer
 - Thus, the term **Default Router** would be suited better

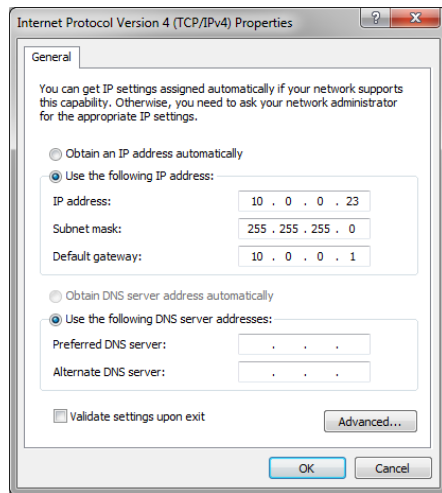

Collision Domain – Routers and Layer-3-Switches

- Routers and Layer-3-Switches divide the collision domain
 - Exactly like Bridges and Layer-2-Switches do

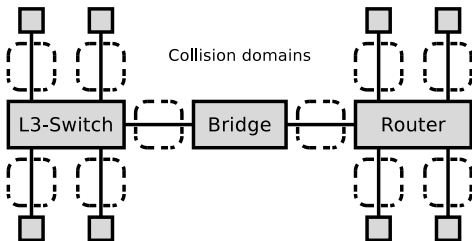

- Devices, which operate on layer 1 (**Repeaters, Hubs**) do not divide the collision domain
- Devices, which operate on layer 2 and 3 (**Bridges, Layer-2-Switches, Routers, Layer-3-Switches**) divide the collision domain

Broadcast Domain (1/2)

- Logical part of a computer network, where a broadcast reaches all network devices that belong to that part
 - Devices, which operate on layer 3 (**Routers**) divide the broadcast domain
 - Devices, which operate on layer 1 and 2 (**Repeaters, Hubs, Bridges, Layer-2-Switches**) do not divide it
 - From the perspective of logical networks, they work transparent

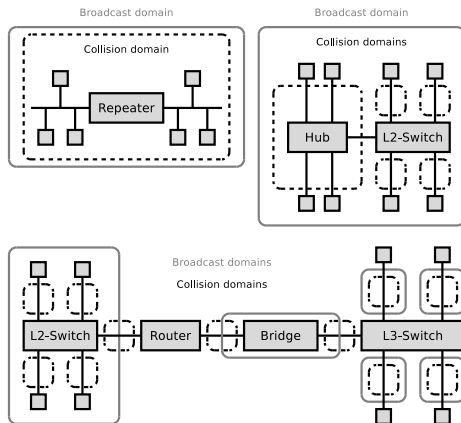

The technical term broadcast domain...

always applies to the Network Layer and never to the Data Link Layer (although broadcasts exist also in the Data Link Layer)

Addressing in the Network Layer (1/2)

- Using only physical addressing via MAC addresses is not useful in large-scale computer networks with possibly global proportions
 - Reason: Maintainability
- **Logical addresses** are required, which are independent from the specific hardware
 - Logical addressing separates the view of humans (logical addresses) from the internal view of computers and software (physical addresses)

Addressing in the Network Layer (2/2)

- Every Network Layer packet contains the IP address of the receiver
 - The structure of IP addresses is specified by the Internet Protocol (IP)

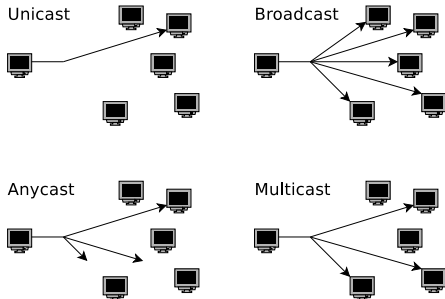

- An IP address can be assigned to a single receiver (**unicast**) or a group of receivers (**multicast** or **broadcast**)
- Multiple IP addresses can be assigned to a single network device

- If **Anycast** is used, a single device of a group of devices can be reached via a single address
 - The receiver, which can be accessed via the shortest route, responds

Multicast is used for example by the routing protocols RIPv2 and OSPF and by Network Time Protocol (NTP) that is used for clock synchronization

Anycast is used for example by some Root Name Servers in the Domain Name System

Format of IP Addresses

- IPv4 addresses have a length of 32 bits (4 bytes)
 - Thus, the address space contains $2^{32} = 4,294,967,296$ possible addresses

Address space = amount of all valid network identifiers

- The usual representation is the so-called **dotted decimal notation**
 - The 4 octets are written as decimal integers in the range from 0 to 255, which are separated from each other by points
Example: 141.52.166.25

Address Classes, Network Identifier and Host Identifier

- Originally, IPv4 addresses were categorized into classes from A to C
 - Additionally, the classes D and E for special purposes existed
- A 32 bits long IPv4 address consists of 2 fields:
 - Network identifier** (network ID)
 - Host identifier** (host ID)
 - Class A: 7 bits for the network ID and 24 bits for the host ID
 - Class B: 14 bits for the network ID and 16 bits for the host ID
 - Class C: 21 bits for the network ID and 8 bits for the host ID

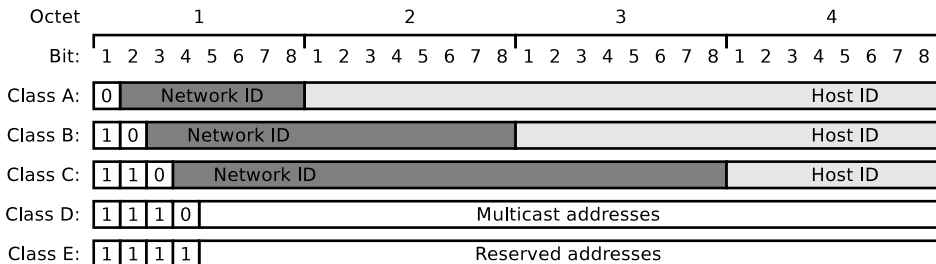

Address Classes (1/2)

- The prefixes specify the address classes and their address ranges

Class	Prefix	Address range	Network ID	Host ID
A	0	0.0.0.0 - 127.255.255.255	7 bits	24 bits
B	10	128.0.0.0 - 191.255.255.255	14 bits	16 bits
C	110	192.0.0.0 - 223.255.255.255	21 bits	8 bits
D	1110	224.0.0.0 - 239.255.255.255	—	—
E	1111	240.0.0.0 - 255.255.255.255	—	—

- $2^7 = 128$ class A networks with a maximum of $2^{24} = 16,777,216$ host addresses each
- $2^{14} = 16,384$ class B networks with a maximum of $2^{16} = 65,536$ host addresses each
- $2^{21} = 2,097,152$ class C networks with a maximum of $2^8 = 256$ host addresses each
- Class D contains multicast addresses (e.g. for IPTV)
- Class E is reserved for future (?!) purposes and experiments

Why is the class E address space of IPv4 not used?

"The class E space has 268 million addresses and would give us in the order of 18 months worth of IPv4 address use. However, many TCP/IP stacks, such as the one in Windows, do not accept addresses from class E space and will not even communicate with correspondents holding those addresses. It is probably too late now to change this behavior on the installed base before the address space would be needed."

Source: http://www.cisco.com/web/about/ac123/ac147/archived_issues/ipj_10-3/103_addr-cons.html

Address Classes (2/2)

- Only the classes A, B and C are relevant in practice
- The original intention was to identify physical networks in a unique way via the network ID
 - This approach causes some drawbacks
- **Drawbacks of Address Classes:**
 - It is impossible to dynamically adjust them
 - Many addresses are wasted
 - A class C network with 2 devices wastes 253 addresses
 - The address space of class C networks is quite small
 - A class B network with 256 devices wastes $> 64,000$ addresses
 - Only 128 class A networks exist
 - Migrating multiple devices to a different network class is a complex task
- Solution: Logical networks are divided into **subnets**
 - 1993: Introduction of the **Classless Interdomain Routing (CIDR)**

Subnet Mask

Class B IP address



Subnet mask (255.255.248.0)

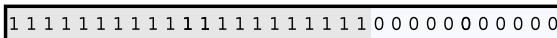

A part of the hosts IP address includes the subnet identifier



- For creating subnets, a **(sub-)netmask** is required
 - All hosts in a network have a subnet mask assigned
 - Length: 32 bits (4 bytes) \implies Specifies the number of subnets and hosts
 - It splits the host ID of an IP addr. into **subnet ID** and **host ID**
 - The network ID remains unchanged
 - Subnet mask adds another level of hierarchy into the IP address
- Structure of the subnet mask:
 - 1-bits indicate, which part of the address space is used for subnet IDs
 - 0-bits indicate, which part of the address space is used for host IDs

Example: Splitting a class B network into 20 subnets requires 5 bits

- Each subnet requires its own subnet ID and it must be represented in binary form
- If 5 bits are used for the representation of the subnet IDs, 11 bits remain for host IDs

Syntax of the Classless Interdomain Routing (CIDR)

- Since **CIDR** was introduced in 1993, IP address ranges are assigned in this notation: **First address/mask bits**
 - The number of mask bits indicates the number of 1-bits (prefix) in the subnet mask
- The table shows the possible splits of a class C network into subnets

Mask bits (prefix)	/24	/25	/26	/27	/28	/29	/30	/31	/32
Subnet mask	0	128	192	224	240	248	252	254	255
Subnet bits	0	1	2	3	4	5	6	7	8
Subnets IDs	1	2	4	8	16	32	64	128	256
Host bits	8	7	6	5	4	3	2	1	0
Host IDs	256	128	64	32	16	8	4	2	—
Hosts (maximum)	254	126	62	30	14	6	2	0	—

2 Host IDs cannot be assigned to network devices, because each (sub-)network requires. . .

- an address for the network itself (all host ID bits are 0 bits)
- a broadcast address to address all devices in network (all bits of the host ID are 1 bits)

2 subnet IDs should not be used

- The subnet IDs, consisting exclusively of 0 bits and 1 bits should not be used
 ⇒ This rule is obsolete, but still often followed
- Modern Routers allow assigning all possible subnet IDs to subnets

Determining the required Subnet Bits

Mask bits (prefix)	/24	/25	/26	/27	/28	/29	/30	/31	/32
Subnet mask	0	128	192	224	240	248	252	254	255
Subnet bits	0	1	2	3	4	5	6	7	8
Subnets IDs	1	2	4	8	16	32	64	128	256
Host bits	8	7	6	5	4	3	2	1	0
Host IDs	256	128	64	32	16	8	4	2	—
Hosts (maximum)	254	126	62	30	14	6	2	0	—

- By using the table, it is simple to determine the required bits for subnets

Example: Subdivide a class C network into 5 subnets, each with a maximum of 25 hosts

- Each subnet requires a subnet address
- For representing 5 subnets, 3 subnet bits are required
- The remaining 5 bits are used for representing the host IDs and they allow the addressing of $32 - 2 = 30$ hosts per subnet
- Thus, the subnet mask with the prefix /27 is well suited for this use case

Calculation example for Subnetting

Example: 172.21.240.90/27 is a class B address (\implies see prefix)

The number behind the slash is the number of 1 bits in the subnet mask

- **IP address AND subnet mask = subnet address**

1 AND 1 = 1, 1 AND 0 = 0, 0 AND 1 = 0, 0 AND 0 = 0

IP address	172.21.240.90	10101100	00010101	11110000	01011010
Subnet mask	255.255.255.224	11111111	11111111	11111111	11100000
Subnet address	172.21.240.64	10101100	00010101	11110000	01000000
Subnet ID	1922	10101100	00010101	11110000	01000000

- **IP address AND (NOT subnet mask) = host ID**

IP address	172.21.240.90	10101100	00010101	11110000	01011010
Subnet mask	255.255.255.224	11111111	11111111	11111111	11100000
Inverse subnet mask	000.000.000.31	00000000	00000000	00000000	00011111
Host ID	26	00000000	00000000	00000000	00011010

/27 and class B prefix \implies 11 bits for the subnet ID

- 5 bits and therefore $2^5 = 32$ addresses remain for the host IDs
- 30 of these addresses can be assigned to network devices

Some questions. . . (5)

• Addressing in the Network Layer

- Calculate the first and last host addresses, the network address and the broadcast address of the subnet.

```

IP Address:      153.213.11.213    10011001.11010101.00001011.11010101
Subnet mask:    255.255.255.224    11111111.11111111.11111111.11100000
Network address?  ---.---.---.---                -----.-----'.-----'.-----
First host address? ---.---.---.---                -----.-----'.-----'.-----
Last host address? ---.---.---.---                -----.-----'.-----'.-----
Broadcast address? ---.---.---.---                -----.-----'.-----'.-----
  
```

```

IP Address:      130.120.20.123    10000010.01111000.00010100.01111011
Subnet mask:    255.255.240.0      11111111.11111111.11110000.00000000
Network address?  ---.---.---.---                -----.-----'.-----'.-----
First host address? ---.---.---.---                -----.-----'.-----'.-----
Last host address? ---.---.---.---                -----.-----'.-----'.-----
Broadcast address? ---.---.---.---                -----.-----'.-----'.-----
  
```

binary representation	decimal representation	binary representation	decimal representation
10000000	128	11111000	248
11000000	192	11111100	252
11100000	224	11111110	254
11110000	240	11111111	255

Some questions. . . (7)

• Addressing in the Network Layer

- The sender transmits an IP packet to a receiver. Calculate the subnet ID of sender and receiver and specify whether the IP packet leaves the subnet during transmission or not.

Sender: 10000100.10011000.01010011.11111110 132.152.83.254
 Subnet mask: 11111111.11111111.11111100.00000000 255.255.252.0

Receiver: 10000100.10011000.01010001.00000010 132.152.81.2
 Subnet mask: 11111111.11111111.11111100.00000000 255.255.252.0

Subnet ID of sender?

Subnet ID of receiver?

Does the IP packet leave the subnet [yes/no]?

Sender: 11010010.00000101.00010000.11000110 210.5.16.198
 Subnet mask: 11111111.11111111.11111111.11111100 255.255.255.252

Sender: 11010010.00000101.00010000.11001001 210.5.16.201
 Subnet mask: 11111111.11111111.11111111.11111100 255.255.255.252

Subnet ID of sender?

Subnet ID of receiver?

Does the IP packet leave the subnet [yes/no]?

Example (1/4)

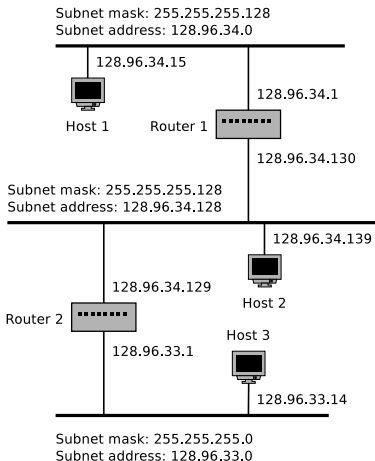

- All hosts inside the same subnet have the same subnet mask
- IP address AND subnet mask = subnet address
- If a host wants to transmit a packet, it calculates the AND of its own subnet mask and the destination IP address
 - If the result is equal to the subnet address of the sender, the sender learns that the destination is inside the same subnet
 - If the result does not match the subnet address of the sender, the packet must be transmitted to a Router, which forwards it to another subnet

Source: Computernetzwerke. Peterson and Davie. dpunkt (2000)

Example (2/4)

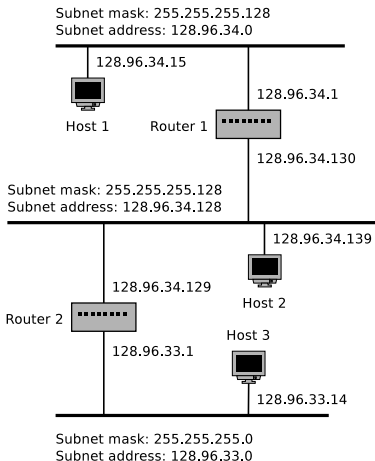

- Example: Host 1 transmits a packet to host 2 (128.96.34.139)
- Host 1 calculates subnet mask (255.255.255.128) AND destination address (128.96.34.139). Result: 128.96.34.128
- This is not the subnet of host 1
 \implies Host 2 is in a different subnet
- Host 1 transmits the packet to its default Router (128.96.34.1)
- Entries in the routing table of Router 1

Subnet address	Subnet mask	Next hop
128.96.34.0	255.255.255.128	Port 0
128.96.34.128	255.255.255.128	Port 1
128.96.33.0	255.255.255.0	Router 2

- Routing protocols/algorithms (\implies see slide set 8) create and maintain the entries in the routing tables inside the Routers

Source: Computernetzwerke. Peterson and Davie. dpunkt (2000)

Example (3/4)

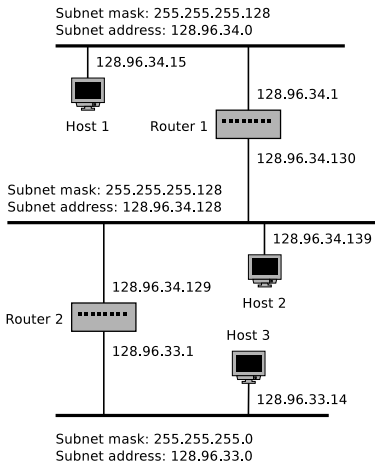

• Entries in the routing table of Router 1

Subnet address	Subnet mask	Next hop
128.96.34.0	255.255.255.128	Port 0
128.96.34.128	255.255.255.128	Port 1
128.96.33.0	255.255.255.0	Router 2

- The Router calculates the destination address AND subnet mask for each entry (row)
- If the result is equal to the subnet address of one entry, the Router forwards the packet to the corresponding Router or port
- Router 1 calculates for the 1st row: Host 2 (128.96.34.139) AND subnet mask (255.255.255.128) \implies 128.96.34.128
- This result does not match the subnet address (128.96.34.0) inside the routing table

Source: Computernetzwerke. Peterson and Davie. dpunkt (2000)

Example (4/4)

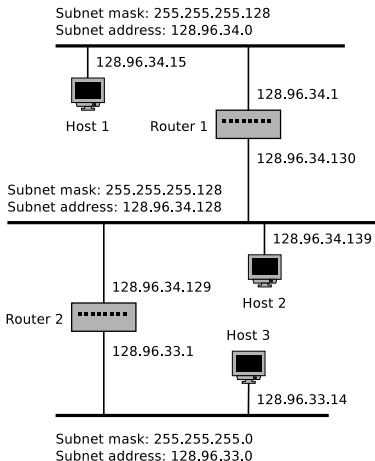

- Entries in the routing table of Router 1

Subnet address	Subnet mask	Next hop
128.96.34.0	255.255.255.128	Port 0
128.96.34.128	255.255.255.128	Port 1
128.96.33.0	255.255.255.0	Router 2

- Router 1 calculates for the 2nd row: Host 2 (128.96.34.139) AND subnet mask (255.255.255.128) \Rightarrow 128.96.34.128
- This result is equal to the subnet address entry in the forwarding table \Rightarrow The 2nd row is a hit
- Router 1 transmits the packet via port 1 to host 2, because this port is connected to the same network as host 2

Where do the forwarding table records come from?

The forwarding table records are created via path determination (**routing**) using **routing protocols**

Source: Computernetzwerke. Peterson and Davie. dpunkt (2000)

Private Networks – Private IP Address Spaces

- In private networks, it is also required to assign IPs to network devices
 - These addresses are not allowed to interfere with global accessible internet services
- Several address spaces exist, containing private IP addresses
 - These address spaces are **not routed** in the internet

Address space: 10.0.0.0 to 10.255.255.255

CIDR notation: 10.0.0.0/8

Number of addresses: $2^{24} = 16,777,216$

Address class: Class A. 1 private network with 16,777,216 addresses

Address space: 172.16.0.0 to 172.31.255.255

CIDR notation: 172.16.0.0/12

Number of addresses: $2^{20} = 1,048,576$

Address class: Class B. 16 private networks with 65,536 addresses each

Address space: 192.168.0.0 to 192.168.255.255

CIDR notation: 192.168.0.0/16

Number of addresses: $2^{16} = 65,536$

Address class: Class C. 256 private networks with 256 addresses each

Structure of IPv4 Packets (1/4)

- **Version** (4 bits)

- Protocol version

- Version = 4 \implies IPv4
 - Version = 6 \implies IPv6

- **IHL** = IP Header Length (4 bits)

- Header length, represented as the number of 4 byte words
 - Example: IHL = 5 \implies 5 * 4 bytes = 20 bytes
 - Indicates where the payload begins

- **Differentiated services** (8 bits)

- Prioritization of IP packets is possible with this field (Quality of Service)
 - The field slightly changed over the years (RFC 791, RFC 2474, RFC 3168)

- **Total length** (16 bits)

- This field specifies the packet size (header and payload)

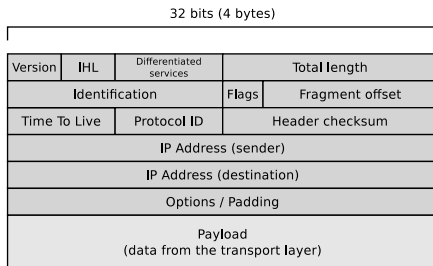

Structure of IPv4 Packets (2/4)

- The fields **Identification**, **Flags** and **Fragment offset** control the assembly of fragmented IP packets
- **Identification** (16 bits)
 - Contains a unique identifier of the IP packet

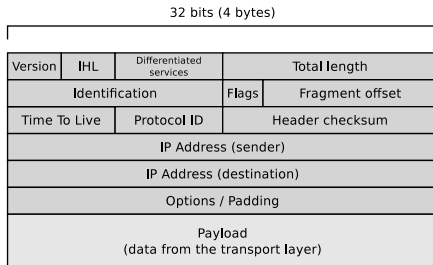

- **Flags** (3 bits)
 - Here the sender informs whether the packet can be fragmented and the receiver is informed whether more fragments follow
- **Fragment Offset** (13 bits)
 - Contains a number which states for fragmented packets, from which position of the unfragmented packet the fragment begins

More information about the fragmentation of IP packages provide the slides 80 + ??

Structure of IPv4 Packets (3/4)

• Time To Live (8 bits)

- Contains the maximum number of hops
- Each Router decrements the value by one
- Prevents undeliverable IP packets to endlessly cycle in the network

• Protocol ID (8 bits)

- Contains the number of the Transport Layer protocol used
- ICMP message \implies 1, TCP segments \implies 6, UDP segments \implies 17, OSPF message \implies 89

• Each IPv4 packet contains a checksum (16 bits) of the header

- Because at each Router on the way to the destination, the content of the field **Time To Live** changes, each Router needs to verify the checksum, recalculate and insert it into the header

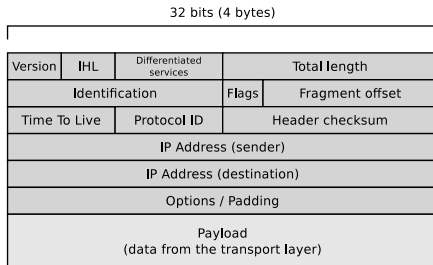

Routers usually ignore the checksum to speed up the packet forwarding

Therefore, IPv6 packets contain no checksum field

Structure of IPv4 Packets (4/4)

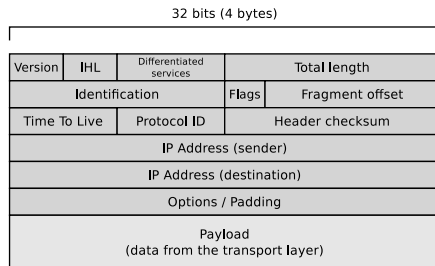

- The field **IP address (sender)** (32 bits) contains the source address and **IP address (destination)** contains the destination address
- The field **Options / Padding** can contain additional information such as a time stamp
 - This last field before the payload area is filled with padding bits (0 bits) if necessary, to ensure that the header size is an integer number of 32 bit words
- The last field contains the data from the Transport Layer

Packet Fragmentation

- The split up (and reassembling) of IP packets into smaller packets (**fragments**) is called **Packet fragmentation**
 - Is usually done by Routers
 - Packet fragmentation can also be carried out by the sender
- Reason for packet fragmentation:
 - The maximum packet length depends on the network technology used
 - The **Maximum Transmission Unit** (MTU) specifies the maximum payload of a frame (and thus the maximum size of an IP packet too)
 - MTU of Ethernet: usually 1,500 bytes
 - MTU of WLAN (IEEE 802.11): 2,312 bytes
 - MTU of PPPoE (e.g. DSL): $\leq 1,492$ bytes
- If a network device does not receive all fragments of an IP packet within a certain period of time (a few seconds), the network device discards all received fragments
- Routers can split IP packets into smaller fragments, if the MTU makes this necessary and it is not prohibited in the packets
 - Only the receiver can assemble fragments

ICMP Messages

- The field **Type** in the ICMP header specifies the ICMP message type
- The field **Code** specifies the subtype of the message type
- The table contains some type-code combinations of ICMP messages

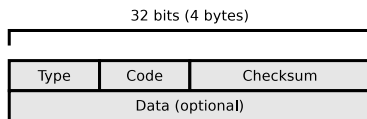

Type	Name of type	Code	Description
0	Echo reply	0	Echo reply (reply for ping)
3	Destination unreachable	0	Destination network unreachable
		1	Destination host unreachable
		2	Destination protocol unreachable
		3	Destination port unreachable
		4	Fragmentation required, but forbidden by the IP packet's flags
5	Redirect	13	Firewall at destination site rejects the IP packet
		0	Router informs sender about a better route (IP of first hop) to destin. network
8	Echo Request	1	Router informs sender about a better route (IP of first hop) to destination host
		0	Echo request (ping)
11	Time Exceeded	0	TTL (Time To Live) expired (exceeded in transit)
		1	Fragment reassembly time exceeded

The ICMP protocol includes many more type-code combinations (see RFC 792), but most were seldom or never used in practice and are considered deprecated (see RFC 6633 and RFC 6918)

Example of using ICMP: traceroute (1/3)

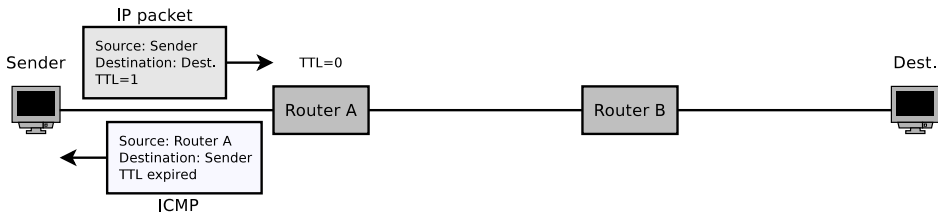

- Another application example of ICMP is the tool traceroute
- traceroute determines, which Routers are used to forward packets to the destination site
- The sender transmits an IP packet to the destination with TTL=1
- Router A receives the IP packet, sets TTL=0, discards the IP packet and transmits an ICMP message of message type 11 and code 0 to the sender

Example of using ICMP: traceroute (2/3)

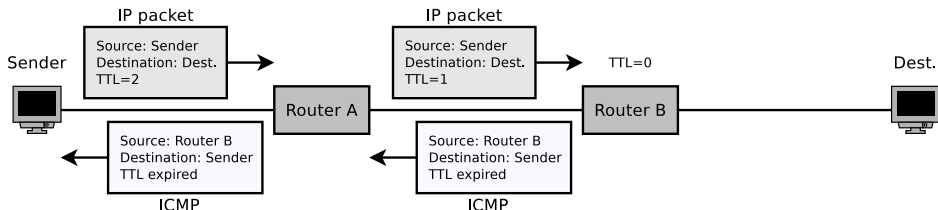

- Next, the sender transmits an IP packet to the destination with TTL=2
- The IP packet is forwarded by Router A and thereby the value of TTL is decremented
- Router B receives the IP packet, sets TTL=0, discards the IP packet and transmits an ICMP message of message type 11 and code 0 to the sender

Example of using ICMP: traceroute (3/3)

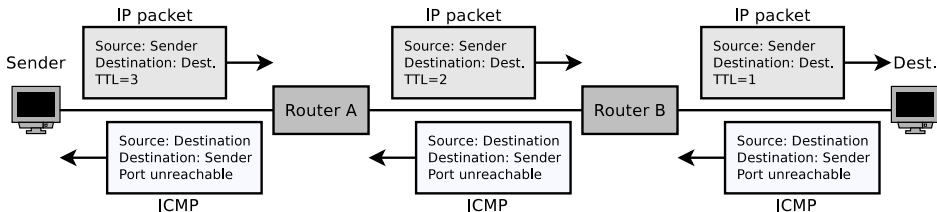

- Once the value of TTL is big enough that the destination site can be reached, the receiver transmits an ICMP message of message type 3 and code 3 to the sender
- This way, the path from sender to receiver can be traced via ICMP

```
$ traceroute -q 1 wikipedia.de
traceroute to wikipedia.de (134.119.24.29), 30 hops max, 60 byte packets
 1 fritz.box (10.0.0.1) 1.834 ms
 2 p3e9bf6a1.dip0.t-ipconnect.de (62.155.246.161) 8.975 ms
 3 217.5.109.50 (217.5.109.50) 9.804 ms
 4 ae0.cr-polaris.fra1.bb.godaddy.com (80.157.204.146) 9.095 ms
 5 ae0.fra10-cr-antares.bb.gdinf.net (87.230.115.1) 11.711 ms
 6 ae2.cgn1-cr-nashira.bb.gdinf.net (87.230.114.4) 13.878 ms
 7 ae0.100.sr-jake.cgn1.dcnnet-emea.godaddy.com (87.230.114.222) 13.551 ms
 8 wikipedia.de (134.119.24.29) 15.150 ms
```

Structure of IPv6 Addresses and Networks (1/5)

- IPv6 addresses have a length of 128 bits (16 bytes)
 - Therefore, $2^{128} \approx 3.4 * 10^{38}$ addresses can be represented
 - The introduction is useful because of the limited address space of IPv4
 - Problem: The decimal notation is confusing
 - For this reason, IPv6 addresses are represented in hexadecimal format
 - Groups of 4 bits are represented as a hexadecimal number
 - Groups of 4 hexadecimal numbers are merged into blocks
 - The blocks are separated by colons
- Example: 2001:0db8:85a3:08d3:1319:8a2e:0370:7344

- The last 4 bytes (32 bits) of an IPv6 address may also be written in decimal notation
- This is useful to embed the IPv4 address space into the IPv6 address space
⇒ see slide 90

Structure of IPv6 Addresses and Networks (2/5)

- Rules for simplification (RFC 5952):
 - Leading zeros within a block may be omitted
 - Successive blocks with value 0 (= 0000), may be omitted **exactly 1 time within an IPv6 address**
 - If blocks are omitted, this is indicated by 2 consecutive colons
 - If several groups of zero blocks exist, it is recommended to shorten the group with the most zero blocks
- Example:
 - The IPv6 address of `j.root-servers.net` is:
2001:0503:0c27:0000:0000:0000:0002:0030
⇒ 2001:503:c27::2:30

Notation of IPv6 addresses (URLs)

- IPv6 addresses are enclosed in square brackets
- Port numbers are appended outside the brackets
`http://[2001:500:1::803f:235]:8080/`
- This prevents the port number from being interpreted as part of the IPv6 address

Structure of IPv6 Addresses and Networks (3/5)

- IPv6 addresses consist of 2 parts

64 Bits	64 Bits
Network Prefix	Interface Identifier
2001:638:208:ef34	:0:ff:fe00:65

1 Prefix (Network Prefix)

- Identifies the network

2 Interface identifier (Interface ID)

- Identifies a network device in a network
- Can be manually set, assigned via DHCPv6 or calculated from the MAC address of the network interface
- If the interface identifier is calculated from the MAC address, it is called **Extended Unique Identifier (EUI)**
 - When this is done, the MAC address (48 bits) is converted into a 64-bit address \implies **modified EUI-64 address format** (see slide 88)

Some address spaces

fe80::/10 \implies Link local addresses. They are only valid in the local network and are therefore not forwarded by Routers

2000::/3 \implies (2000... until 3fff...) Global unicast addresses. Routers forward them

ff00::/8 \implies All addresses ff... are multicast addresses. Since IPv6 has no broadcast addresses, multicast addresses implement the broadcast functionality. The addresses ff01::1 and ff02::1 address all nodes in the local network and the addresses ff01::2, ff02::2 and ff05::2 address all local Routers

2001:db8::/32 \implies Addresses only for documentation purposes

Structure of IPv6 Addresses and Networks (4/5)

- Converting a MAC address in the modified EUI-64 address format
 - 1 The MAC address is split into 2 parts of 24 bits
 - The 1st part becomes the first 24 bits
 - The 2nd part becomes the final 24 bits of the modified EUI-64 address
 - 2 The free 16 bits in the middle of the EUI-64 address have the following bit pattern: 1111 1111 1111 1110 (hex: FFFE)
 - 3 Finally, the value of the seventh bit from the left is inverted

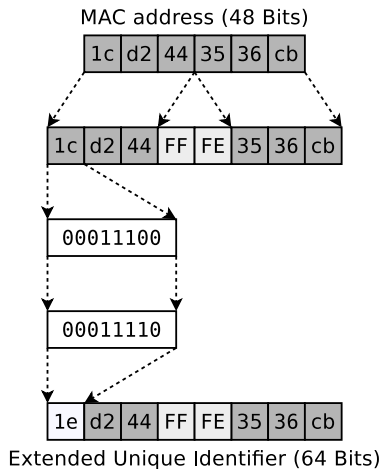

Structure of IPv6 Addresses and Networks (5/5)

- (Sub-)netmasks do not exist in IPv6
 - The subdivision of address ranges into subnets is done by specifying the prefix length
- IPv6 networks are specified in CIDR notation
 - The address of a single device sometimes has /128 attached
 - An example is the loopback address of IPv6: ::1/128
 - All bits – except the last one – have value 0
(For IPv4, the loopback address is: 127.0.0.1)
 - Internet Providers (ISPs) or operators of large networks get the first 32 or 48 bits assigned from a Regional Internet Registry (RIR)
 - The ISPs or network operators split this address space into subnets
 - **End users usually get a /64 or even a /56 network assigned**

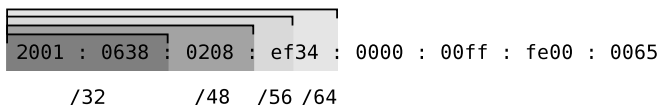

- If a user gets a /56 network assigned, the 8 Bits between the Prefix and the Interface Identifier are the **Subnet Prefix**

Embed IPv4 Addresses into IPv6 (*IPv4 mapped*)

- A globally routed (unicast) IPv4 address can be represented as an IPv6 address and thus integrated into the IPv6 address space
 - In literature, this approach is called *IPv4 mapped*
- The IPv4 address gets a 96 Bits long prefix:
0:0:0:0:0:FFF::/96

80 Bits					16 Bits	32 Bits
0000	0000	0000	0000	0000	FFFF	IPv4 address

- The IPv4 address may be represented in hexadecimal or decimal notation

- Example

IPv4 address:	131.246.107.35
IPv6 address:	0:0:0:0:0:FFF:83F6:6B23
Shorter notation:	::FFF:83F6:6B23
	::FFF:131.246.107.35

Structure of IPv6 Packets

- The size of the IPv6 header is fixed (320 bits \Rightarrow 40 bytes)

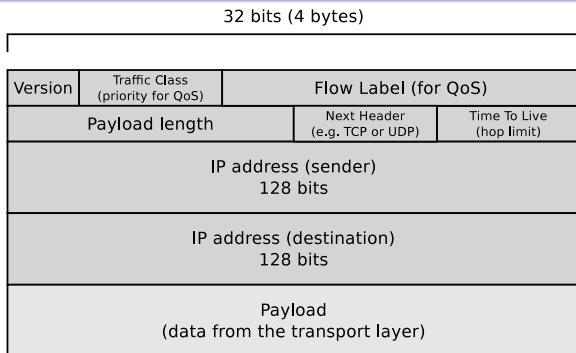

- The field **next header** points to an extension header field or identifies the Transport Layer protocol (e.g. TCP = type 6 or UTP = type 17) which is carried in the payload of the packet

Concept: Simplified (reduced) package structure, but simple option to add additional (new) features with a chain of extension headers

IPv6 extension headers (see RFC 2460 and RFC 4303) are not discussed in this course

Internetworking (1/6)

- **Internetworking** = communication between network devices with the protocols of the Data Link Layer and Network Layer through networks, which may base on different networking technologies
- Possible scenario for internetworking

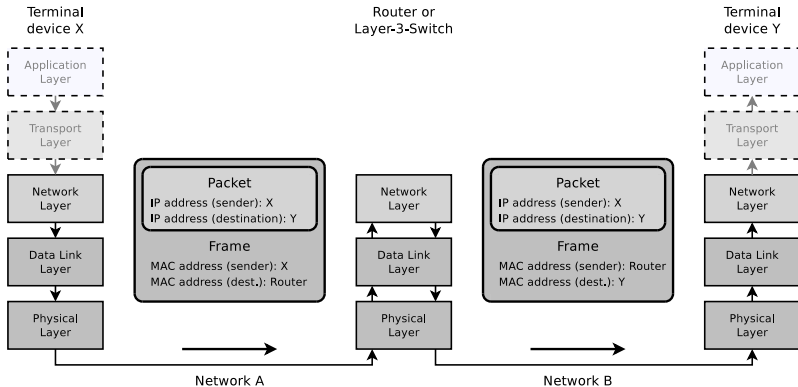

Internetworking (2/6)

In this scenario, all communication partners have public IP address!

- X wants to transmit an IP packet to Y
 - To do this, X needs to know the **logical address** (IP address) of Y

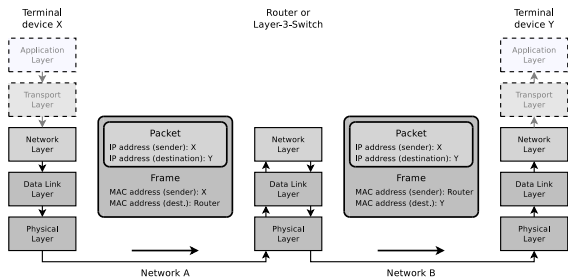

You already know (from slide set 4)...

For the forwarding on the Data Link Layer, the **physical address** (MAC address) is required too

- X calculates the subnet IDs (\implies slide set 7)
 - $\text{subnet mask}_X \text{ AND IP address}_X = \text{subnet ID of the own network}$
 - $\text{subnet mask}_X \text{ AND IP address}_Y = \text{subnet ID of the network where Y is}$

Internetworking (3/6)

- Identical subnet IDs \implies X and Y are in the same logical subnet

You already know (from slide set 7)...

A logical subnet covers at least one physical network and can only be connected with one interface of a Router

- Different subnet IDs \implies X and Y are in different logical subnets

You already know (from slide set 6)...

If 2 communication partners are in the same logical and physical network, the sender can discover the MAC address of the receiver via address resolution with ARP

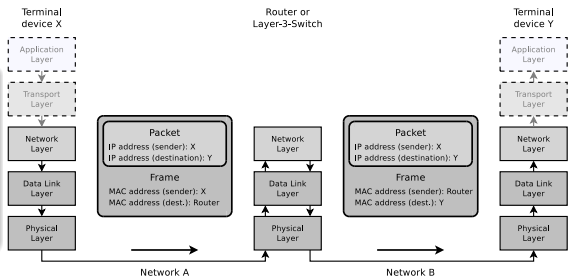

- **In this scenario we have communication across logical and physical network boundaries**

Internetworking (4/6)

You already know (from slide set 6)...

- ARP is only suited for the resolution of MAC addresses in the local physical network
- Reason: ARP requests are sent in frames of the Data Link Layer
- The destination address field contains the broadcast address
- Bridges and Switches do not forward such frames
 ⇒ Therefore, with ARP, cross-network address resolution is impossible

- The frame contains as payload the IP packet for Y with the IP address of X as sender address and the IP address of Y as destination address

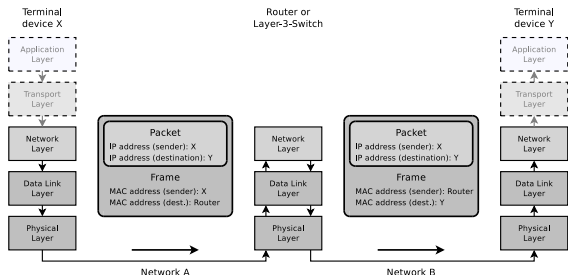

Internetworking (5/6)

- The Router receives the IP packet
 - It finds out with its local routing table the correct interface for forwarding the packet
 - The local routing table contains all logical networks, the Router knows
- The Router is connected via one of its ports with the physical network, to which Y is connected
- The Router finds out the MAC address of Y via address resolution with ARP
- The Router packs the IP packet into a frame
 - The sender address field contains the MAC address of the Router
 - The destination address field contains the MAC address of Y

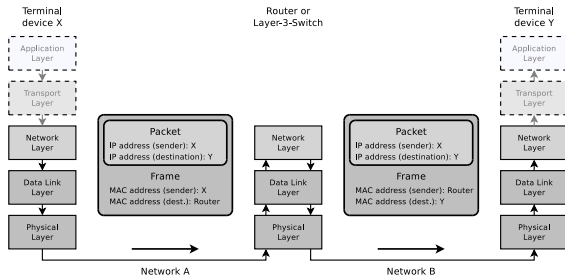

Internetworking (6/6)

- Maybe the maximum packet length (Maximum Transmission Unit) of network B is smaller than the one of network A
 - In this case it may be required, depending on the size of the forwarded IP packet, that the Router fragments (\implies see slide set 7) the received packet into multiple smaller packets

- The IP addresses of the sender (X) and the receiver (Y) in the IP packet are not modified during the transmission

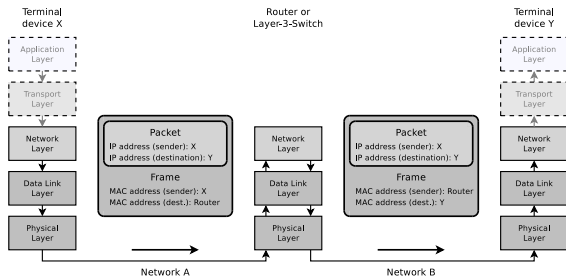

Network Address Translation (1/5)

- Problem: Few households, businesses and educational/research institutions have enough public IPv4 addresses to equip all their network devices with own IPs
 - Therefore, LANs usually use a private IPv4 address space
 - How can network devices in private networks communicate with network devices that have globally accessible addresses?
 - Solution: **Network Address Translation (NAT)**
 - The local Router presents itself as the source of those IP packets that it forwards from the directly connected private network to the Internet
 - In addition, it forwards incoming replies to the participants in the directly connected private networks

Network Address Translation (2/5)

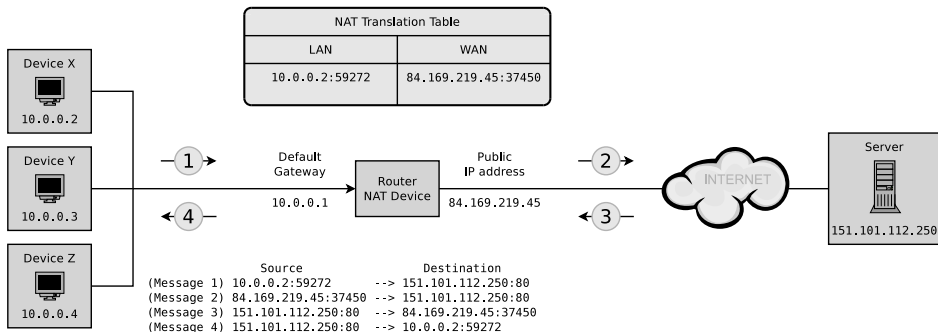

- Clients X, Y, and Z are inside a network with a private IP address range
- Only the Router has a globally accessible IP address
 - It does appear to the outside world as just a network device with a single public IP address and not as a Router

Network Address Translation (3/5)

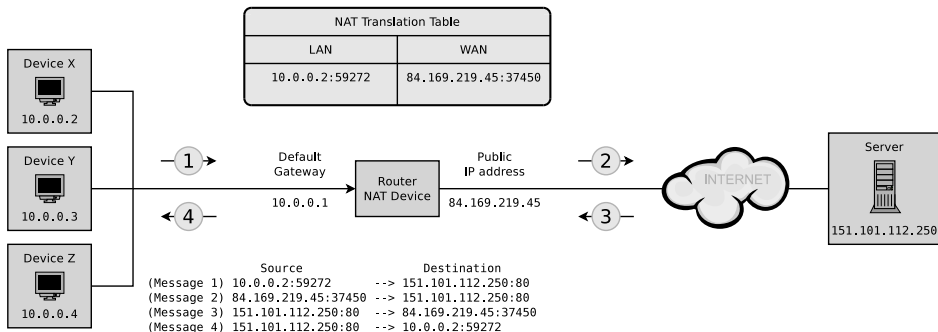

- Client X sends a request for a web page
 - The request (message 1) contains the IP address and port number of X as source addresses and the IP address and port number of the server as destination addresses
- The Router replaces the IP and port number of the client with its own addresses inside the forwarded request (message 2)

Network Address Translation (4/5)

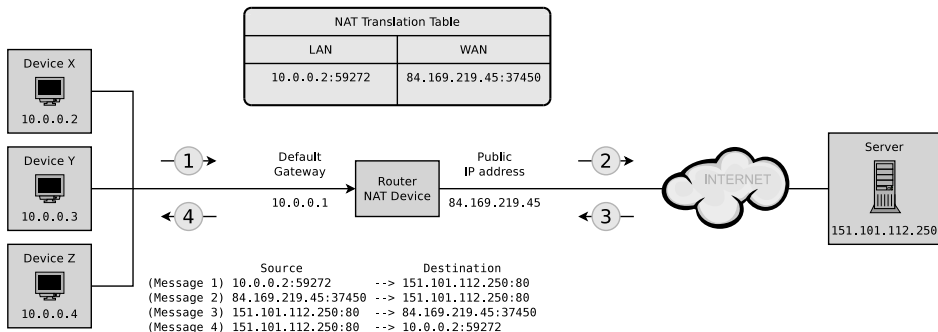

- The Router stores the mappings between the Router ports and the corresponding network devices inside its local **NAT translation table**
- The destination address inside the reply of the server (message 3) is the IP of the Router
 - The Router replaces the address information according to the table and forwards the reply to X (message 4)

Network Address Translation (5/5)

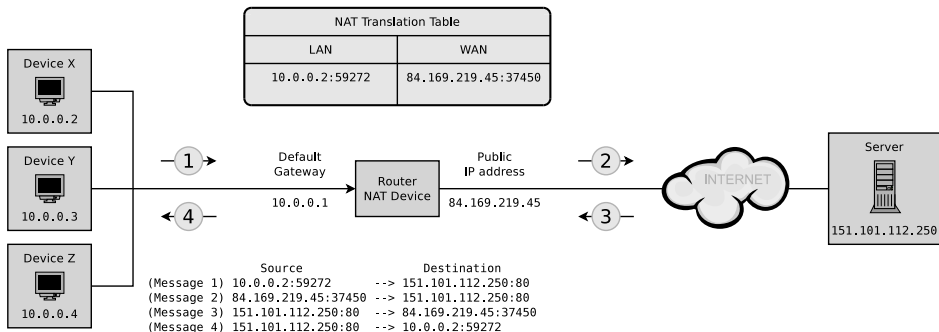

- With IPv6, NAT is unnecessary because the address space is large enough to allocate globally accessible addresses to all network devices
 - Whether this is advisable for reasons of security, is controversial
 - NAT improves network security because it hides the topology of the local network from the outside world
- NAT with IPv6: **IPv6-to-IPv6 Netw. Address Translation (NAT66)**

Contents

- 1 Introduction
- 2 Fundamentals
- 3 Physical Layer
- 4 Data Link Layer
- 5 Network Layer
- 6 Transport Layer**
- 7 Application Layer

Characteristics of Transport Layer Protocols

- Desired characteristics of Transport Layer protocols include. . .
 - guaranteed data transmission
 - ensuring the correct delivery order
 - support for data transmissions of any size
 - the sender must not overload the network
 - It must be able to adjust its own data flow (data rate) \implies flow control
 - the receiver should be able to control the transmission rate of the sender \implies congestion control
- Transport Layer protocols are required which convert the networks' negative characteristics into the (positive) characteristics that are expected of Transport Layer protocols
- The most common used Transport Layer protocols:
 - **UDP**
 - **TCP**
- The addressing is realized via **sockets**

Addressing in the Transport Layer

- Every application which uses TCP or UDP, has a **port number** assigned
 - It specifies which service is accessed
 - For TCP and UDP, the size of port numbers is 16 bits
 - Thus, the range of possible port numbers is from 0 to 65,535
- In principle, port numbers can be assigned as wished
 - Conventions exist, that specify which ports are used by common used applications

Port number	Service	Description
21	FTP	File transfer
22	SSH	Encrypted terminal emulation (secure shell)
23	Telnet	Terminal emulation for remote control of computers
25	SMTP	E-mail transfer
53	DNS	Resolution of domain names into IP addresses
67	DHCP	Assignment of the network configuration to clients
80	HTTP	Webserver
110	POP3	Client access to E-mail server
143	IMAP	Client access to E-mail server
443	HTTPS	Webserver (encrypted)
993	IMAPS	Client access to E-mail server (encrypted)
995	POP3S	Client access to E-mail server (encrypted)

- The table only contains a small selection of well-known port numbers

Ports (2/2)

- The port numbers are divided into 3 groups:
 - 0 to 1023 (Well Known Ports)
 - These are permanently assigned to applications and commonly known
 - 1024 to 49151 (Registered Ports)
 - Application developers can register port numbers in this range for own applications
 - 49152 to 65535 (Private Ports)
 - These port numbers are not registered and can be used freely
- Different applications can use identical port numbers inside an operating system at the same time, if they communicate via different transport protocols
 - In addition, some applications exist, which implement communication via TCP and UDP via a single port number
 - Example: Domain Name System – DNS
- Well Known Ports and Registered Ports are assigned by the Internet Assigned Numbers Authority (IANA)
 - In Linux/UNIX systems, the configuration file `/etc/services` exists
 - Here, the applications (services) are mapped to specific port numbers
 - In Windows systems: `%WINDIR%\system32\drivers\etc\services`

Sockets

- **Sockets** are the platform-independent, standardized **interface** between the implementation of the network protocols in the operating system and the applications
- **A socket consists of a port number and an IP address**
- Stream Sockets and datagram sockets exist
 - **Stream sockets** use the connection-oriented TCP
 - **Datagram sockets** use the connectionless UDP

Tool(s) to monitor the open ports and sockets with...

- Linux/UNIX: `netstat`, `lsof` and `nmap`
- Windows: `netstat`

Alternatives for sockets to implement inter-process communication (IPC)

Pipes, message queues and shared memory \implies see Operating Systems course

User Datagram Protocol (UDP)

- **Connectionless Transport Layer protocol**

- Transmissions take place without previous connection establishment
- More simple protocol in contrast to the connection-oriented TCP
 - Only responsible for addressing of the segments
 - Does not secure the data transmission
- The receiver does not acknowledge transmissions at the sender
 - Segments can get lost during transmission
- Depending on the application (e.g. video streaming) this is accepted
 - If a TCP segment (and therefore some image information) gets lost during the transmission of a video, it is requested again
 - A drawback would be dropouts
 - To compensate for this, a buffer at the receiver site is required
 - Especially video telephony software tries to keep the buffer as small as possible because they cause delays
 - If UDP is used for video transmission or video telephony, the only consequence of losing a segment is losing an image

User Datagram Protocol (UDP)

- Maximum size of an UDP segment: 65,535 Bytes
 - Reason: The size of the **length** field inside the UDP header, which contains the segment length, is 16 bits
 - The maximum representable number with 16 bits is 65,535
 - UDP segments of this size are transmitted in fragments by IP

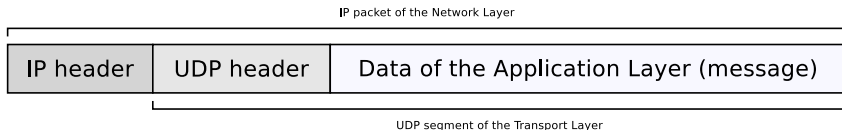

UDP standard: RFC 768 from 1980

<http://tools.ietf.org/rfc/rfc768.txt>

Structure of UDP Segments

- The UDP header consists of 4 fields, each 16 bits in size
 - **Port number (sender)**
 - The field can stay empty (value 0), if no response is required
 - **Port number (destination)**
 - **Length** of the complete segment (without pseudo-header)
 - **Checksum** of the complete segment (including pseudo-header)
- A pseudo-header is created, which includes the IP addresses of sender and destination, as well as some Network Layer information
 - Protocol ID of UDP = 17
- The pseudo-header is not transmitted
 - But it is used for the checksum calculation

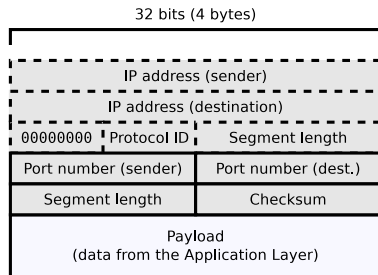

Remember NAT from slide set 8...

If a NAT device (Router) is used, this routing device also needs to recalculate the checksums in UDP segments when doing IP address translations

Transmission Control Protocol (TCP)

- **Connection-oriented Transport Layer protocol**
- Makes connections via IP reliable in a way, which is desired or required for many applications
- Ensures that segments reach their destination **completely** and in the **correct order**
 - Lost or unacknowledged TCP segments are requested by the receiver at the sender and sent again
- TCP connections are opened and closed like files
 - Equal to files, the position in the data stream is precisely specified

TCP standard: RFC 793 from 1981
<http://tools.ietf.org/rfc/rfc793.txt>

Sequence Numbers in TCP

- TCP treats payload as an unstructured, but ordered data stream
- **Sequence numbers** are used for numbering the bytes in the data stream
 - The sequence number of a segment is the position of the segment's first byte in the data stream
- Example
 - The sender splits the Application Layer data stream into segments
 - Length of data stream: 5,000 bytes
 - MSS: 1,460 bytes

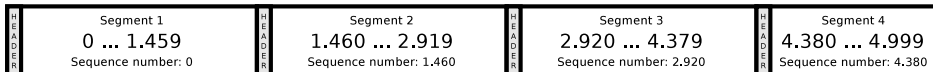

Some key figures...

Maximum Transfer Unit (MTU): Maximum size of the IP packets

MTU of Ethernet = 1,500 bytes, MTU of PPPoE (e.g. DSL) = 1,492 bytes

Maximum Segment Size (MSS): Maximum segment size

MSS = MTU - 40 bytes for IPv4 header and TCP header

Structure of TCP Segments (1/5)

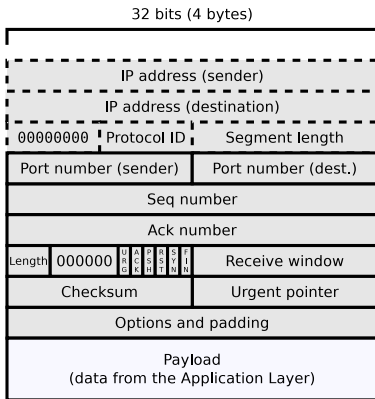

- A TCP segment can contain a maximum of 64 kB payload (data of the Application Layer)
 - Usually, segments are smaller (\leq 1500 bytes for Ethernet)
- The header of TCP segments is more complex compared with UDP segments

Overhead

- Size of the TCP header (without the options field): just 20 bytes
- Size of the IP header (without the options field): also just 20 bytes

⇒ The overhead caused by the TCP and IP headers is small for an IP packet with a size of several kB

Structure of TCP Segments (2/5)

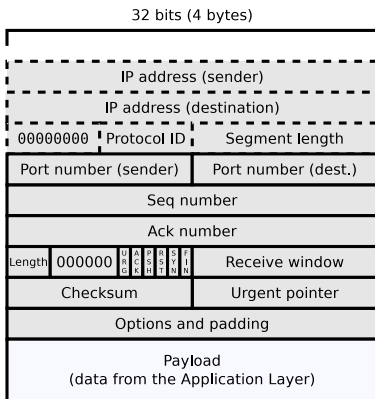

- One field contains the port number of the sender process
- Another field contains the port number of the process which is expected to receive the segment
- **Seq number** contains the sequence number of the current segment
- **Ack number** contains the sequence number of the next expected segment

- The **length** field specifies the size of the TCP header in 32-bit words to tell the receiver where the payload starts in the segment
 - The field is required, because the field options and padding can have a variable length (a multiple of 32 bits)

Structure of TCP Segments (3/5)

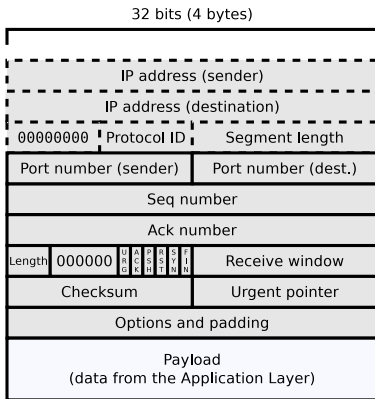

- The field 000000 is 6 bits long and not used
 - It contains per default value zero
- The 6 fields with a size of 1 bit each, are required for connection establishment, data exchange and connection termination
 - The functionality of these fields is described with the assumption that the fiels contain the value 1 \implies it is set

URG (Urgent) is not discussed in this course

- **ACK** (Acknowledge)

- Specifies that the acknowledgement number in **Ack number** is valid
- It is also used to acknowledge the receive of segments

Structure of TCP Segments (4/5)

32 bits (4 bytes)

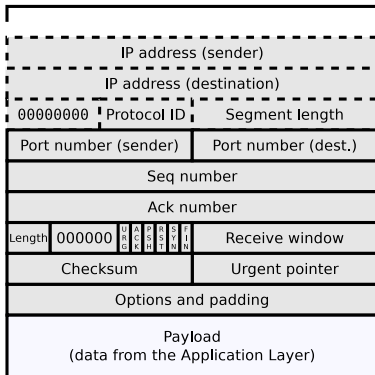

PSH (Push) is not discussed in this course

RST (Reset) is not discussed in this course

- **SYN** (Synchronize)
 - Requests the synchronization of the sequence numbers
 - That initiates the connection establishment
- **FIN** (Finish)
 - Requests the connection termination and indicates that the sender will not send any more payload
- The field **receive window** contains the number of free bytes in the sender's receive window, which is necessary for flow control

Structure of TCP Segments (5/5)

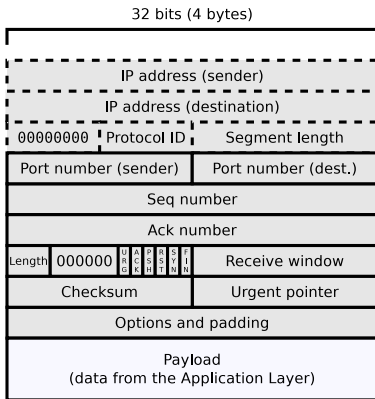

- Just as with UDP, for each TCP segment, a pseudo header exists, which is not transmitted
 - But the pseudo header fields are used together with the regular TCP header fields and the payload to calculate the **checksum**
 - **Protocol ID** of TCP = 6

The **urgent pointer** is not discussed in this course

The field **options and padding** must be a multiple of 32bits and is not discussed in this course

Remember NAT from slide set 8...

If a NAT device (Router) is used, this routing device also needs to recalculate the checksums in TCP segments when doing IP address translations

Functioning of TCP

You already know...

- Each segment has a unique **sequence number**
- The sequence number of a segment is the position of the segment's first byte in the data stream
- The sequence number enables the receiver to...
 - correct the order of the segments
 - sort out segments, which arrived twice
- The length of a segment is known from the IP header
 - This way, missing bytes in the data stream are discovered and the receiver can request lost segments
- To establish a connection, TCP uses a **three-way handshake**, where both communication partners exchange control information in three steps
 - This ensures that the communication partner exists and can accept data transmissions

TCP Connection Establishment (three-way Handshake)

- The server waits passively for an incoming connection

- 1 Client sends a segment with $SYN=1$ as a request to synchronize the sequence numbers

⇒ Synchronize

- 2 Server sends as confirmation a segment with $ACK=1$ and requests with $SYN=1$ to synchronize the sequence numbers too

⇒ Synchronize Acknowledge

- 3 Client confirms with a segment with $ACK=1$ that the connection is established

⇒ Acknowledge

- The initial sequence numbers (x and y) are determined randomly
- No payload is exchanged during connection establishment!

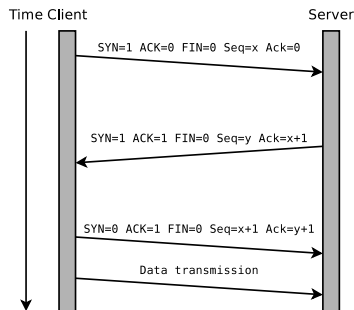

TCP Data Transmission

To demonstrate a data transmission, **Seq number** (sequence number of the current segment) and **Ack number** (sequence number of the next expected segment) need particular values

- In our example at the beginning of the three-way handshake, the client's sequence number is $x=100$ and the server's sequence number is $y=500$
- After completion of the three-way handshake: $x=101$ and $y=501$

- 1 The client transmits 1000 bytes payload
- 2 Server acknowledges with $ACK=1$ the received payload and requests with the Ack number 1101 the next segment. In the same segment, the server transfers 400 bytes of payload
- 3 The client transmits another 1000 bytes payload. And it acknowledges the received payload with the ACK bit set and requests with the Ack number 901 the next segment
- 4 Server acknowledges with $ACK=1$ the received payload and requests with the Ack number 2101 the next segment

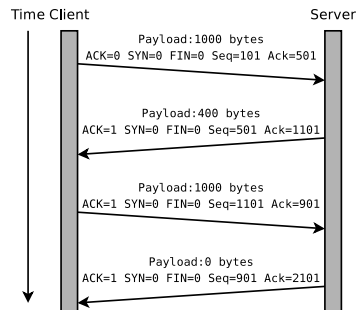

TCP Connection Termination

- Connection termination is similar to the connection establishment
- Instead of the SYN bit set, the FIN bit is used to indicate that the sender will not transmit any more payload

- 1 The client sends the request for connection termination with $FIN=1$
- 2 The server sends an acknowledgment with $ACK=1$
- 3 The server sends the request for connection termination with $FIN=1$
- 4 The client sends an acknowledgment with $ACK=1$

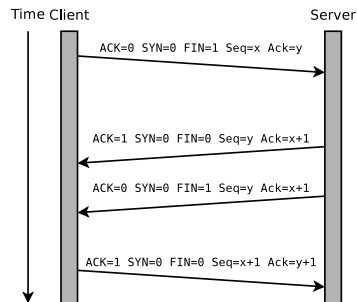

- No payload is exchanged during connection termination!

Contents

- 1 Introduction
- 2 Fundamentals
- 3 Physical Layer
- 4 Data Link Layer
- 5 Network Layer
- 6 Transport Layer
- 7 Application Layer**

Application Layer

- Contains the protocols, which interact with applications (e.g. browser or email client)
- Contains the messages of the users and their applications (e.g. HTML pages or emails) in accordance with the Application Layer protocol used

TCP/IP Reference Model

Hybrid Reference Model

OSI Reference Model

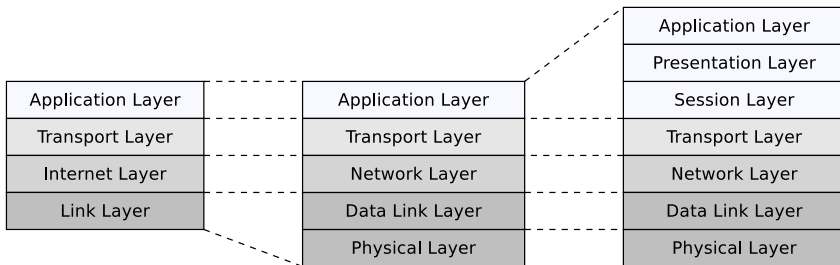

- Devices: none
- Protocols: DNS, DHCP, NTP, Telnet, SSH, HTTP, SMTP, FTP...

Dynamic Host Configuration Protocol (DHCP)

- Is used to assign the network configuration (IP address, network mask, default gateway, name server, etc.) to network devices from a **DHCP server** by using a **DHCP client**
 - Especially for mobile devices, it is not useful to assign static IPs
 - Without DHCP, the network settings of all clients need to be customized after modifying the network topology
 - With DHCP, just the DHCP server's configuration needs to be adjusted
- Uses UDP via ports 67 (server or relay agent) and 68 (client)

RFC 2131

- A DHCP server has a **pool of IPs** and distributes them to clients
- A DHCP client can only use a DHCP server, when both are connected to the **same logical network**
 - Reason: DHCP uses **broadcasts** and Routers do not forward broadcasts

If the DHCP server is connected with a different logical network, a **DHCP relay** needs to forward the requests to the DHCP server

Functioning of DHCP (1/2)

- 1 A client without an IP address sends a request (**DHCP Discover**) via **broadcast** to the DHCP servers, that can be reached by it
 - The sender IP address of the broadcast is 0.0.0.0 and the destination address is 255.255.255.255
- 2 Each DHCP server, which receives the **broadcast** and has free IPs in its pool, responds to the request with an address offer (**DHCP Offer**)
 - The address offer is sent as **broadcast** (destination address: 255.255.255.255) or **unicast** (to the offered IP address)
 - Whether broadcast or unicast is used depends on if the client has set the broadcast bit in the DHCP Discover message
- 3 The DHCP client accepts an address offer by sending a request (**DHCP Request**) via **broadcast**
 - The message contains the ID of the desired DHCP server
 - Any other (possibly existing) DHCP servers understand the message as a rejection of their address offers
- 4 The server acknowledges the address request with **DHCP Ack** via **broadcast** or **unicast** and marks the IP in its address pool as assigned
 - Whether broadcast or unicast is used depends on if the client has set the broadcast bit in the DHCP Discover message
 - It can also refuse the request with **DHCP Nak**

Functioning of DHCP (2/2)

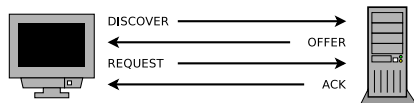

- If a DHCP server has assigned an IP and acknowledged this via **DHCP Ack**, it creates a *lease* record for the address in its database
 - If all addresses are assigned (leased), no further clients can be supplied with IP addresses
- Each address has an expiration date (*lease time*), which is transmitted to the client via the acknowledgement (**DHCP Ack**)
 - Active clients periodically renew the lease after the half lease time has expired via **DHCP Request**, which is sent via **unicast** directly to the server and not via broadcast
 - The server again responds with an acknowledgement (**DHCP Ack**), which contains the same data as before and a new expiration date
 - If the expiration date has expired, the server can assign the address new, when requests arrive

Structure of DHCP Messages

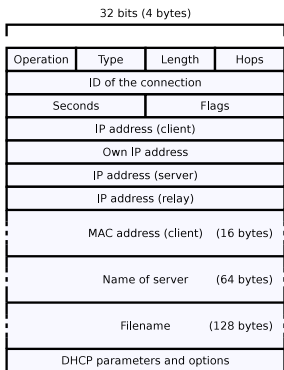

- **Operation** specifies the sort of the DHCP message
 - 1 = Request of a Client
 - 2 = Reply of a Server
- **Type** specifies the networking technology
 - 1 = Ethernet, 6 = WLAN
- **Length** contains the length of the physical network address in bytes
- **Hops** is optional and contains the number of DHCP Relays on the path
- **Flags** indicates if the client still has a valid IP address
- **Filename** is optional and contains the name of a file, which the client is supposed to fetch via Trivial File Transfer Protocol (TFTP)
 - This allows a terminal device to boot via the network

Hypertext Transfer Protocol (HTTP)

- The Hypertext Transfer Protocol (HTTP) is a stateless protocol for data transmission
 - Stateless means that every HTTP message contains all the information necessary to understand the message
 - The server does not maintain any information regarding the state or session for the client, and each request is a transaction, independent of other requests

HTTP

From 1989 onwards, developed by Roy Fielding, Tim Berners-Lee and other at CERN

- Together with the concepts of URL and HTML it is the basis of the World Wide Web (WWW)
- Main purpose: Loading web pages from the World Wide Web (WWW) in a browser
- For communication, HTTP needs a reliable transport protocol
 - In almost all cases, TCP is used
- Each HTTP message consists of:
 - Message header (*HTTP header*): Includes among others information about the encoding, desired language, browser and content type
 - Message body (*body*): Contains the payload, e.g. the HTML source code of a web page

HTTP Requests (1/2)

- If an URL is accessed via HTTP (e.g. `http://www.informatik.hs-mannheim.de/~baun/index.html`, the request for the resource `/~baun/index.html` is transmitted to the computer with hostname `www.informatik.hs-mannheim.de`
- First, via DNS, the hostname is resolved to an IP address
- Next, this HTTP GET request is transmitted via TCP to port 80, where the web server usually operates

```
GET /~baun/index.html HTTP/1.1
Host: www.informatik.hs-mannheim.de
User-Agent: Mozilla/5.0 (X11; U; Linux i686; de; rv:1.9.2.18) Gecko/20110628 Ubuntu/10.10 (
    maverick) Firefox/3.6.18
Accept: text/html,application/xhtml+xml,application/xml;q=0.9,*/*;q=0.8
Accept-Language: de-de,de;q=0.8,en-us;q=0.5,en;q=0.3
Accept-Encoding: gzip,deflate
Accept-Charset: ISO-8859-1,utf-8;q=0.7,*;q=0.7
Keep-Alive: 115
Connection: keep-alive
...
```

HTTP Requests (2/2)

- A message header this large is not required
- The HTTP GET request below is sufficient

```
GET /-baun/index.html HTTP/1.1
Host: www.informatik.hs-mannheim.de
```

- The header of a HTTP message is separated from the message body with a line feed (LF) and a carriage return (CR)
 - In this example, the HTTP request has no message body

HTTP Responses (1/2)

- The HTTP response of the web server consists of a message header and the message body with the actual message
 - In this case, the message body contains the content of the requested file `index.html`

```
HTTP/1.1 200 OK
Date: Sun, 04 Sep 2011 15:19:13 GMT
Server: Apache/2.2.17 (Fedora)
Last-Modified: Mon, 22 Aug 2011 12:37:04 GMT
ETag: "101ec1-2157-4ab17561a3c00"
Accept-Ranges: bytes
Content-Length: 8535
Keep-Alive: timeout=13, max=499
Connection: Keep-Alive
Content-Type: text/html

<!DOCTYPE HTML PUBLIC "-//W3C//DTD HTML 4.01 Transitional//EN"
      "http://www.w3.org/TR/html4/loose.dtd">
<html>
...
</html>
```

HTTP Responses (2/2)

- Each HTTP response contains a **status code**, which consists of 3 digits, and a text string, which describes the reason for the response

Status code	Meaning	Description
1xx	Informational	Request received, continuing process
2xx	Success operation	Action received, understood, accepted and processed successfully
3xx	Redirection	Additional action must be taken by the client to complete the request
4xx	Client error	Request of the client caused an error situation
5xx	Server error	Server failed to fulfill a valid request \implies error was caused by server

- The table contains some common status codes of HTTP

Status code	Meaning	Description
200	OK	Request processed successfully. Result is transmitted in the response
202	Accepted	Request accepted, but will be executed at a later point in time
204	No Content	Request executed successfully. Response intentionally contains no data
301	Moved Permanently	The old address is no longer valid
307	Temporary Redirect	Resource moved. The old address remains valid
400	Bad Request	Request cannot be fulfilled due to bad syntax
401	Unauthorized	Request cannot be executed without a valid authentication
403	Forbidden	Request is executed because of clients lack of privileges
404	Not Found	Server could not find the requested resource
500	Internal Server Error	Unexpected server error

HTTP Protocol Versions (HTTP/1.0 and HTTP/1.1)

- 3 protocol versions exist: HTTP/1.0, HTTP/1.1 and HTTP/2

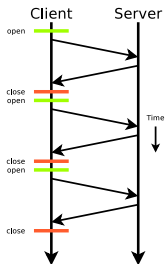

- HTTP/1.0 (RFC 1945): Prior to any request, a new TCP connection is established and closed by default by the server after the transmission of the reply
 - If a HTML document contains e.g. 10 images, 11 TCP connections are required for the transmission to the client

- HTTP/1.1 (RFC 2616): By default, no connection termination is done

- So the connection can be used again and again
- Therefore, only a single TCP connection is required for the transfer of a HTML document with 10 images
 - Result: The document download finishes in a shorter time
- Interrupted transmissions can be resumed with HTTP/1.1

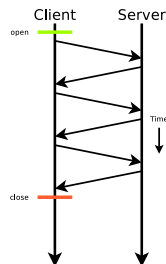

HTTP Protocol Versions (HTTP/2)

- HTTP/2 (RFC 7540) became a standard in May 2015
- Accelerates the data transfer by compressing the header with the HPACK algorithm (RFC 7541)
- Enables the aggregation (*Multiplex*) of requests and a server can send (*Server Push*) data automatically, which it expects the browser to request immediately
 - Examples of such data are CSS files (Cascading Style Sheets), which specify the layout of web pages, or script files
- HTTP/2 is not a text-based but a binary protocol
 - Therefore it cannot be used to communicate using simple tools like telnet and nc e.g. to inspect a server
 - Tools like curl and openssl -connect can communicate via HTTP/2

Some sources about curl and openssl

<https://stackoverflow.com/questions/51278076/curl-one-liner-to-test-http-2-support>

<https://blog.cloudflare.com/tools-for-debugging-testing-and-using-http-2/>

Stephen Ludin, Javier Garza. **Learning HTTP/2: A Practical Guide for Beginners**. O'Reilly Media, Inc (2017)

HTTP Methods

- The HTTP protocol provides some methods for requests

HTTP	Description
PUT	Upload a new resource to the web server
GET	Request a resource from the web server
POST	Upload data to the web server in order to generate resources
DELETE	Erase a resource on the web server
HEAD	Request the header of a resource from the web server, but not the body
TRACE	Returns the request back, as the web server has received it. Helpful for troubleshooting purposes
OPTIONS	Request the list of supported HTTP methods from the web server
CONNECT	Establish a SSL tunnel with a proxy

HTTP is a stateless protocol. But via cookies in the header information, applications can be implemented, which require state or session information, because they assign user information or shopping carts to clients.