

# Sample solution of the written examination in Computer Networks

*February 19th 2020*

Last name: \_\_\_\_\_

First name: \_\_\_\_\_

Student number: \_\_\_\_\_

I confirm with my signature that I will process the written examination alone and that I feel healthy and capable to participate this examination.  
I am aware, that from the moment, when I receive the written examination, I am a participant of this examination and I will be graded.

Signature: \_\_\_\_\_

- Use the provided sheets. Own paper must *not* be used.
- You are allowed to use a *self prepared, single sided DIN-A4 sheet* in the exam. Only *handwritten originals* are allowed, but no copies.
- You are allowed to use a non-programmable calculator.
- Do *not* use a red pen.
- The time limit ist *90 minutes*.
- Turn off your mobile phones!

## Result:

Question:	1	2	3	4	5	6	7	8	9	$\Sigma$	Grade
Maximum points:	17	13	8	7	14	9	8	9	5	90	—
Achieved points:											

**1.0:** 90.0-85.5, **1.3:** 85.0-81.0, **1.7:** 80.5-76.5, **2.0:** 76.0-72.0, **2.3:** 71.5-67.5,  
**2.7:** 67.0-63.0, **3.0:** 62.5-58.5, **3.3:** 58.0-54.0, **3.7:** 53.5-49.5, **4.0:** 49.0-45.0, **5.0:** <45

Last name:

First name:

Student number:

# Question 1)

Points: .....

Maximum points: 12.5+0.5+4=17

a) Fill out all empty fields. (*Only one correct answer per field!*)

### Hybrid Reference Model

	Layer	Protocol	Device	Sort of Data (data unit)	Addresses
7	<b>Application Layer</b>	<b>SMTP, HTTP, POP3, SSH...</b>	<b>none (evtl. Appliance)</b>	<b>Message</b>	<b>none (evtl. DNS)</b>
4	<b>Transport Layer</b>	<b>TCP, UDP</b>	<b>(VPN-)Gateway</b>	<b>Segment</b>	<b>Port nummer</b>
3	<b>Network Layer</b>	<b>IP, ICMP</b>	<b>Router, L3-Switch</b>	<b>Packet</b>	<b>IP address</b>
2	<b>Data Link Layer</b>	<b>Ethernet, Wifi, Bluetooth, PPP...</b>	<b>Bridge, L2-Switch, Modem</b>	<b>Frame</b>	<b>MAC address</b>
1	<b>Physical Layer</b>	<b>Ethernet, Wifi, Bluetooth...</b>	<b>Repeater, Hub</b>	<b>Signal</b>	<b>none</b>

b) Do computer networks usually implement parallel or serial data transmission?  
*Serial data transmission.*

c) Calculate the first and last host addresses, the network address and the broadcast address of the subnet.

IP Address:                    153.213.11.213    10011001.11010101.00001011.11010101  
Subnet mask:                   255.255.255.224   11111111.11111111.11111111.11100000

Part for host IDs: xxxxx

Network address?    153.213.11.192    10011001.11010101.00001011.11000000  
First host address?  153.213.11.193    10011001.11010101.00001011.11000001  
Last host address?  153.213.11.222    10011001.11010101.00001011.11011110  
Broadcast address?  153.213.11.223    10011001.11010101.00001011.11011111

binary representation	decimal representation	binary representation	decimal representation
10000000	128	11111000	248
11000000	192	11111100	252
11100000	224	11111110	254
11110000	240	11111111	255

Last name:

First name:

Student number:

# Question 2)

Points: .....

Maximum points: 2+2+2+2+5=13

- a) Simplify this IPv6 address:  
21da:00d3:0000:0000:02aa:00ff:fe28:9c5a

*Solution:* 21da:d3::2aa:ff:fe28:9c5a

- b) Simplify this IPv6 address:  
2001:0db8:0000:0000:5a6b:0000:0001:678a

*Solution:* 2001:db8::5a6b:0:1:678a

- c) Provide all positions of this simplified IPv6 address:  
2001:db8:84a2::8a2e:70:4

*Solution:* 2001:0db8:84a2:0000:0000:8a2e:0070:0004

- d) Provide all positions of this simplified IPv6 address:  
2001:cdba::18:2

*Solution:* 2001:cdba:0000:0000:0000:0000:0018:0002

- e) This signal curve is encoded with NRZI and 4B5B. Decode the data.

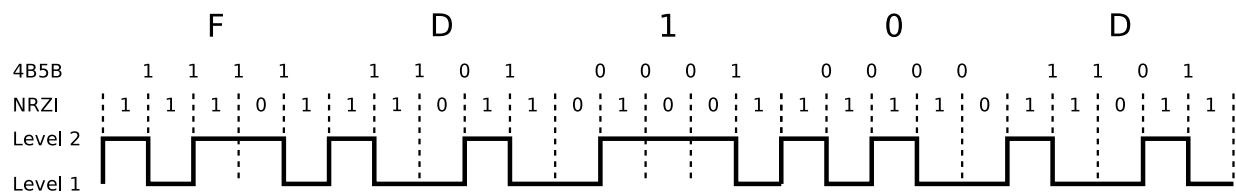

Label	4B	5B	Function
0	0000	11110	0 hexadecimal
1	0001	01001	1 hexadecimal
2	0010	10100	2 hexadecimal
3	0011	10101	3 hexadecimal
4	0100	01010	4 hexadecimal
5	0101	01011	5 hexadecimal
6	0110	01110	6 hexadecimal
7	0111	01111	7 hexadecimal

Label	4B	5B	Function
8	1000	10010	8 hexadecimal
9	1001	10011	9 hexadecimal
A	1010	10110	A hexadecimal
B	1011	10111	B hexadecimal
C	1100	11010	C hexadecimal
D	1101	11011	D hexadecimal
E	1110	11100	E hexadecimal
F	1111	11101	F hexadecimal

Last name:

First name:

Student number:

# Question 3)

Points: .....

Maximum points: 4+4=8

- a) Error detection via CRC: Calculate the frame to be transferred.

Generator polynomial: 100101

Payload: 110100110110

*The generator polynomial has 6 digits  $\implies$  five 0 bits are appended*

Frame with appended 0 bits: 11010011011000000

```

11010011011000000
100101|||||
-----v|||||
 100011|||||
 100101|||||
-----vvv|||||
   110101|||||
   100101|||||
   -----v|||||
     100001|||||
     100101|||||
     -----vvv|||
       100000|||
       100101|||
       -----vvv
         101000
         100101
         -----
           1101 = Remainder

```

Remainder: 1101

Transferred frame: 11010011011001101

- b) Error detection via CRC: Check, if the received frame was transmitted correctly.

Transferred frame: 1011010110100

Generator polynomial: 100101

```

1011010110100
100101|||||
-----vv|||||
  100001|||||
  100101|||||
-----vvv|||
   100101|||
   100101|||
   -----vv
     00 => Transmission was error-free

```

Last name:

First name:

Student number:

---

# Question 4)

Points: .....

Maximum points: 3+4=7

- a) Error Correction via simplified Hamming Distance (Hamming ECC method). Calculate the message, that will be transmitted (payload inclusive parity bits).

Payload: 10111110

*Step 1: Determine parity bit positions:*

Position:	1	2	3	4	5	6	7	8	9	10	11	12
Data to be transmitted:	?	?	1	?	0	1	1	?	1	1	1	0

*Step 2: Calculate parity bit values:*

```

0011 Position 3
0110 Position 6
0111 Position 7
1001 Position 9
1010 Position 10
XOR 1011 Position 11
-----
1010 = parity bit values

```

*Step 3: Insert parity bit values into the transmission:*

Position:	1	2	3	4	5	6	7	8	9	10	11	12
Data to be transmitted:	1	0	1	1	0	1	1	0	1	1	1	0

- b) Error Correction via simplified Hamming Distance (Hamming ECC method). Verify, if the received message was transmitted correctly.

Received message: 101110100010

Received data:	1	2	3	4	5	6	7	8	9	10	11	12
	1	0	1	1	1	0	1	0	0	0	1	0

```

0011 Position 3
0101 Position 5
0111 Position 7
XOR 1011 Position 11
-----
1010 Parity bits calculated
XOR 1010 Parity bits received
-----
0000 => Correct transmission

```

Last name:

First name:

Student number:

# Question 5)

Points: .....

Maximum points: 4+5+5=14

a) The diagram shows the establishment of a TCP connection. Complete the table.

Message	ACK flag	SYN flag	FIN flag	Payload length	Seq number	Ack number
1	0	1	0	0	30	?
2	1	1	0	0	150	31
3	1	0	0	0	31	151

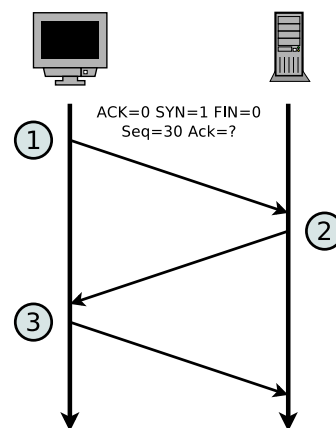

b) The diagram shows an excerpt of the transmission phase of a TCP connection. Complete the table.

Message	ACK flag	SYN flag	FIN flag	Payload length	Seq number	Ack number
4	0	0	0	250	2200	850
5	1	0	0	150	850	2450
6	1	0	0	450	2450	1000
7	1	0	0	10	1000	2900

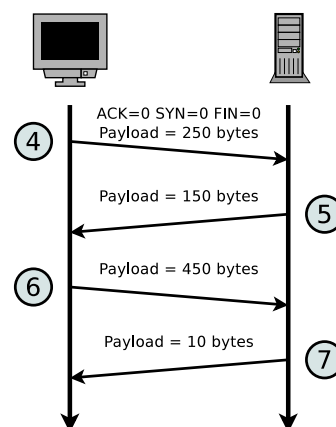

c) The diagram shows the termination of a TCP connection. Complete the table.

Message	ACK flag	SYN flag	FIN flag	Payload length	Seq number	Ack number
8	0	0	1	0	2800	4200
9	1	0	0	0	4200	2801
10	0	0	1	0	4200	2801
11	1	0	0	0	2801	4201

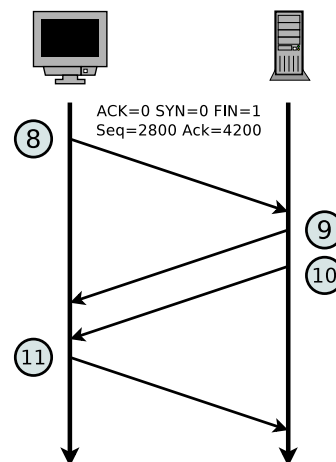

Last name:

First name:

Student number:

# Question 6)

Points: .....

Maximum points: 9

6500 bytes payload need to be transmitted via the IP protocol.

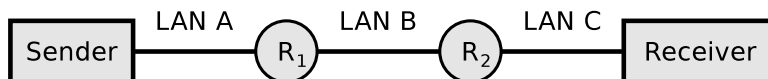

The payload must be fragmented, because it is transmitted over multiple physical networks, whose MTU is < 6500 bytes.

	LAN A	LAN B	LAN C
Network technology	WLAN	Ethernet	PPPoE
MTU [bytes]	2312	1500	1492
IP header [bytes]	20	20	20
max. payload [bytes]	2292	1480	1472

Display graphically the way, the payload is fragmented, and how many bytes of payload each fragment contains.

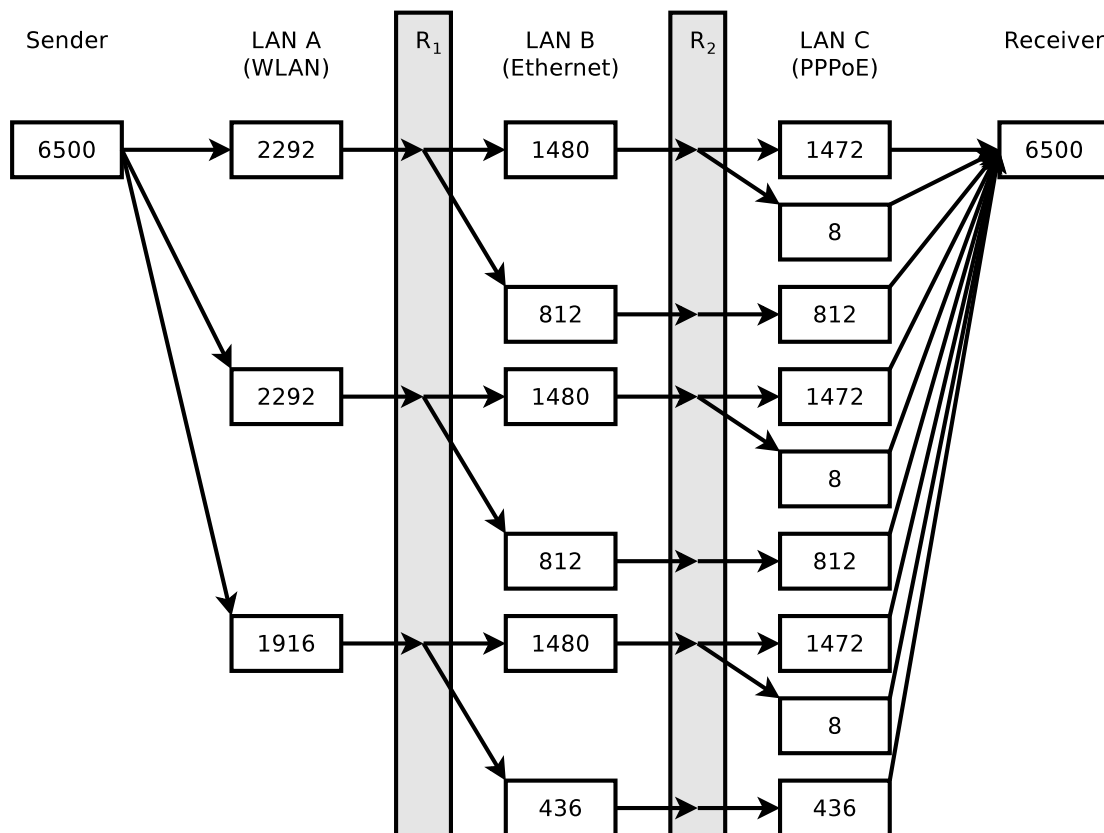

Last name:

First name:

Student number:

# Question 7)

Points: .....

Maximum points: 8

- a) Fill the missing IP addresses and port numbers into the figure that describes a NAT scenario where device E sends a request for an email to an email server process that runs on device X and can be accessed on device X via port number 25.

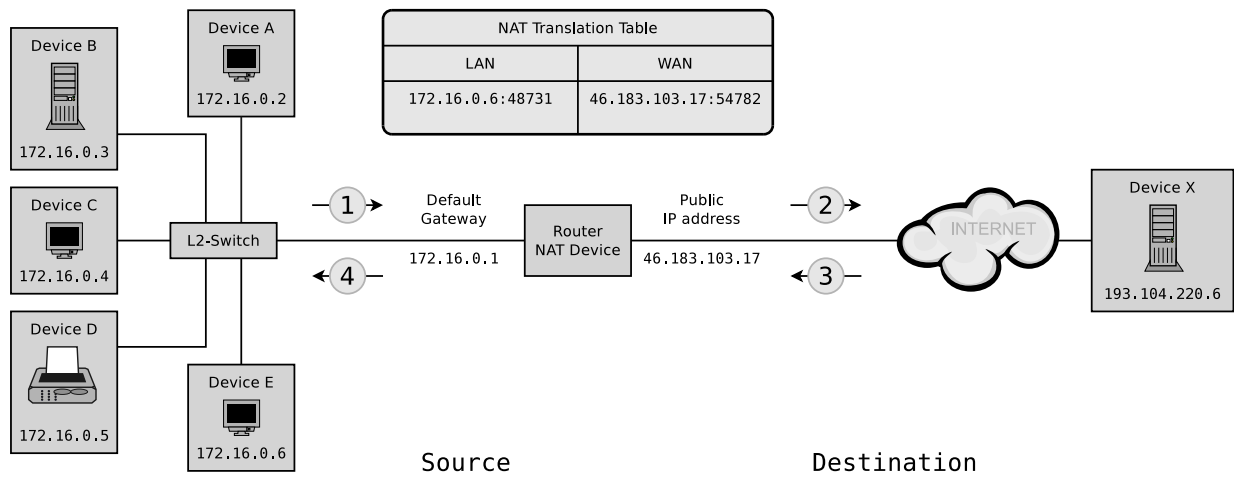

- (Message 1) 172.16.0.6:48731 --> 193.104.220.6:25
- (Message 2) 46.183.103.17:54782 --> 193.104.220.6:25
- (Message 3) 193.104.220.6:25 --> 46.183.103.17:54782
- (Message 4) 193.104.220.6:25 --> 172.16.0.6:48731



Last name:

First name:

Student number:

---

# Question 8)

Points: .....

Maximum points: 9

a) Sketch in the diagram of the network topology all collision domains.

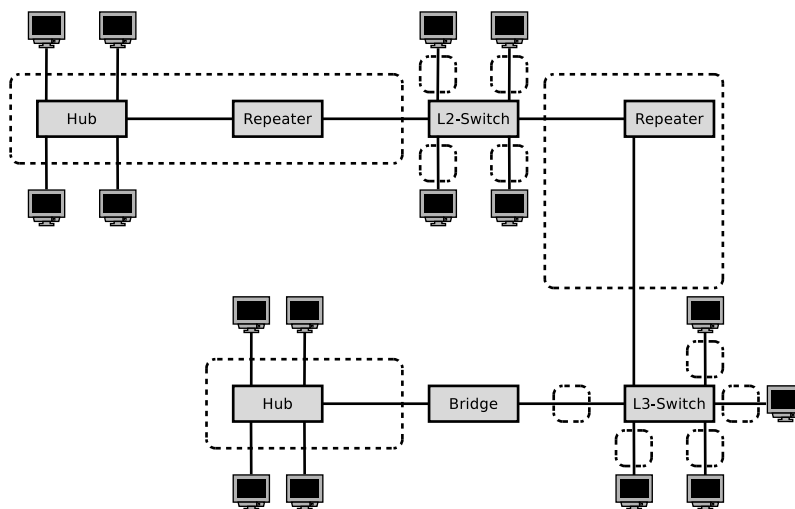

b) Sketch in the diagram of the network topology all broadcast domains.

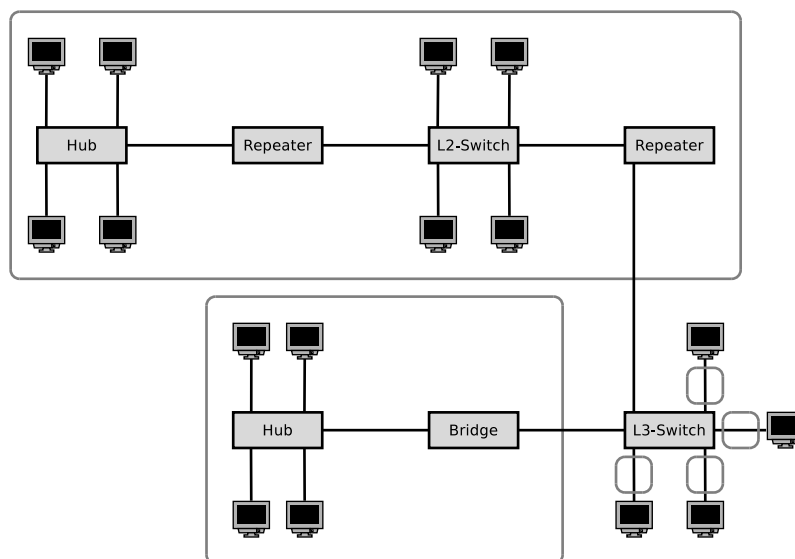

Last name:

First name:

Student number:

# Question 9)

Points: .....

Maximum points: 5

Encode the bit sequence with 5B6B and NRZ and draw the signal curve.

Bit sequence: 11010 11110 01001 00010 01110

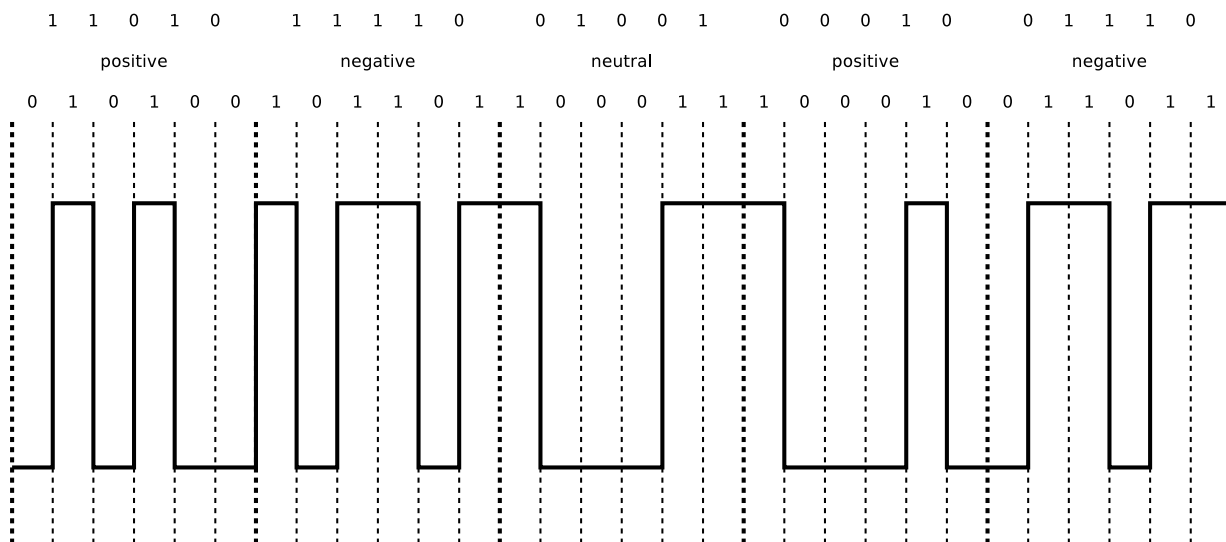

5B	6B neutral	6B positive	6B negative
00000		001100	110011
00001	101100		
00010		100010	101110
00011	001101		
00100		001010	110101
00101	010101		
00110	001110		
00111	001011		
01000	000111		
01001	100011		
01010	100110		
01011		000110	111001
01100		101000	010111
01101	011010		
01110		100100	011011
01111	101001		

5B	6B neutral	6B positive	6B negative
10000		000101	111010
10001	100101		
10010		001001	110110
10011	010110		
10100	111000		
10101		011000	100111
10110	011001		
10111		100001	011110
11000	110001		
11001	101010		
11010		010100	101011
11011	110100		
11100	011100		
11101	010011		
11110		010010	101101
11111	110010		