

# Sample solution of the written examination in Computer Networks

*February 13th 2023*

**Last name:** \_\_\_\_\_

**First name:** \_\_\_\_\_

**Student number:** \_\_\_\_\_

Mit dem Bearbeiten dieser schriftlichen Prüfung (Klausur) bestätigen Sie, dass Sie diese alleine bearbeiten und dass Sie sich gesund und prüfungsfähig fühlen. Mit dem Erhalt der Aufgabenstellung gilt die Klausur als angetreten und wird bewertet.

By attending this written exam, you confirm that you are working on it alone and feel healthy and capable to participate. Once you have received the examination paper, you are considered to have participated in the exam, and it will be graded.

- Use the provided sheets. Do *not* use own paper.
- You are allowed to use a *self prepared, single sided DIN-A4 sheet* in the exam. Only *hand-written originals* are allowed, but no copies.
- Do *not* use a red pen.
- Time limit: *90 minutes*
- Turn off your mobile phones!

**Grade:** \_\_\_\_\_

Questions:	1	2	3	4	5	6	7	8	9	$\Sigma$
Maximum Points:	15	9	8	9	16	8	9	9	7	90
Achieved Points:										

**1.0:** 90.0-85.5, **1.3:** 85.0-81.0, **1.7:** 80.5-76.5, **2.0:** 76.0-72.0, **2.3:** 71.5-67.5,  
**2.7:** 67.0-63.0, **3.0:** 62.5-58.5, **3.3:** 58.0-54.0, **3.7:** 53.5-49.5, **4.0:** 49.0-45.0, **5.0:** <45

# Question 1)

Points: ..... of 15

4 Points

- (1) An image has a size of 3840x2160 pixels (Ultra HD) with true color (3 Bytes per pixel are used for the color information). Calculate how long it takes to transmit the uncompressed image via a 100 Mbps (= 100 \* 10<sup>6</sup> Bits per second) DSL connection.

*Bytes per image: (1 point)*

$$3840 \times 2160 \text{ pixels} = 8,294,400 \text{ pixels}$$

$$8,294,400 \text{ pixel} * 3 \text{ Bytes per pixel} = 24,883,200 \text{ Bytes per image}$$

*Bits per image: (1 point)*

$$24,883,200 \text{ Bytes} * 8 = 199,065,600 \text{ Bits per image}$$

*Transfer time: (2 points)*

$$\frac{199,065,600 \text{ Bits}}{100,000,000 \text{ Bits/s}} = 1,990656 \text{ s} \approx 2 \text{ s}$$

11 Points

- (2) Fill out all empty fields.  
(Fill in each empty cell only one correct answer!)

## ISO/OSI Reference Model

	Layer	Protocol	Device	Sort of Data (data unit)	Addresses
7	Application Layer	SMTP, HTTP, POP3, SSH...		Message	
6	Presentation Layer				
5	Session Layer				
4	Transport Layer	TCP, UDP	(VPN-)Gateway	Segment	Port nummer
3	Network Layer	IP, ICMP	Router, L3-Switch	Packet	IP address
2	Data Link Layer	Ethernet, Wifi, Bluetooth, PPP...	Bridge, L2-Switch, Modem	Frame	MAC address
1	Physical Layer	Ethernet, Wifi, Bluetooth...	Repeater, Hub	Signal	

## Question 2)

Points: ..... of 9

1 Point

- (1) Explain the difference between serial and parallel data transmission.  
*A single data line exists, when serial data transmission is used. The bits are transmitted one after another via the bus.*  
*Several data lines exist, when parallel data transmission is used.*

 $\frac{1}{2}$  Point

- (2) Computer networks usually implement. . .  
 *Serial data transmission*       *Parallel data transmission*

 $\frac{1}{2}$  Point

- (3) Data Link Layer protocols specify the format of. . .  
 *physical network addresses*       *logical network addresses*

1 Point

- (4) Explain what the physical topology of a computer network describes.  
*It describes the wiring.*

1 Point

- (5) Explain what the logical topology of a computer network describes  
*It describes the flow of data between the network devices.*

 $\frac{1}{2}$  Point

- (6) Name the topology that is used by modern Ethernet standards.  
*Star*

 $\frac{1}{2}$  Point

- (7) Name the topology that is used by Thin and Thick Ethernet.  
*Bus*

 $\frac{1}{2}$  Point

- (8) Name the topology that is used by Token Ring (physical).  
*Star*

 $\frac{1}{2}$  Point

- (9) Name the topology that is used by Token Ring (logical).  
*Ring*

 $\frac{1}{2}$  Point

- (10) Name the topology that is used by WLAN without an Access Point.  
*Mesh*

 $\frac{1}{2}$  Point

- (11) Name the topology that is used by WLAN with an Access Point.  
*Cellular*

 $\frac{1}{2}$  Point

- (12) Name one topology that contains a single point of failure.  
*Bus (the medium!), Ring (the medium!), Star, Cellular*

 $\frac{1}{2}$  Point

- (13) Name the topology that is used by mobile phones (GSM standard).  
*Cellular*

 $\frac{1}{2}$  Point

- (14) Name one topology where a cable failure causes the entire network to fail.  
*Ring, Bus*

 $\frac{1}{2}$  Point

- (15) Name one topology that has no central component.  
*Bus, Ring, Mesh*

# Question 3)

Points: ..... of 8

4 Points

- (1) Error Detection via CRC: Check, if the received frame was transmitted correctly.

```

Received frame: 1101001111100      Generator polynomial: 100101
1101001111100
100101|||||
-----v|||||
100011|||||
100101|||||
-----vvv|||
110111|||
100101|||
-----v||
100101||
100101||
-----vv
00 => Transmission was error-free
    
```

4 Points

- (2) Transmission errors can be detected via CRC checksums. If it is important to not only recognize errors, but also to be correct them, then the data to be transmitted must be encoded in a way, that error-correction is possible. Error correction can be realized e.g. via the Simplified Hamming Code we discussed in the computer networks course.

Verify, if the following message was transmitted correctly: 00111101

```

Received data: 1 2 3 4 5 6 7 8
                0 0 1 1 1 1 0 1
    
```

```

0011 Position 3
0101 Position 5
XOR 0110 Position 6
-----
0000 Parity bits calculated
XOR 0011 Parity bits received
-----
0011 => Bit 3 ist defective!
    
```

# Question 4)

Points: ..... of 9

4,000 bytes payload need to be transmitted via the IP protocol.

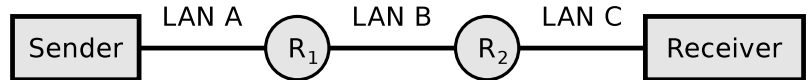

The payload must be fragmented, because it is transmitted over multiple physical networks, whose MTU is < 4,000 bytes.

	LAN A	LAN B	LAN C
Network technology	Ethernet	PPPoE	WLAN
MTU [bytes]	1,500	1,492	2,312
IP header [bytes]	24	20	28
max. payload [bytes]	1,476	1,472	2,284

*Hint: In practice, the fragment offset is counted in 8-byte increments; therefore, the payload in a fragment must be a multiple of 8. However, for the sake of simplicity, you can also create fragments that are not multiples of 8 in this task.*

1½ Points

(1) Calculate the max. payload [bytes] per network and fill the values into the table.

7½ Points

(2) Display graphically the way, the payload is fragmented, and how many bytes of payload each fragment contains.

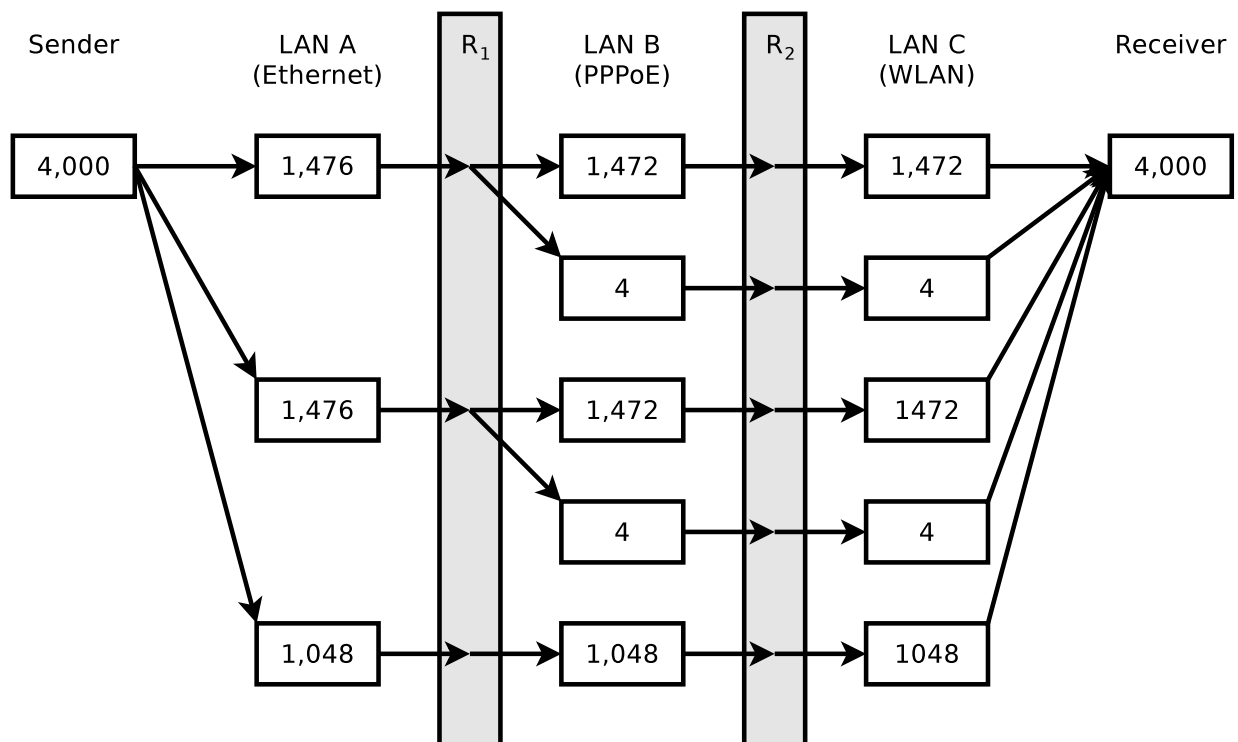

# Question 5)

Points: ..... of 16

8 Points

- (1) Fill the missing IP addresses and port numbers into the figure that describes a NAT scenario where device X sends a request for a web page to a web server process that runs on the server and can be accessed via port number 80.

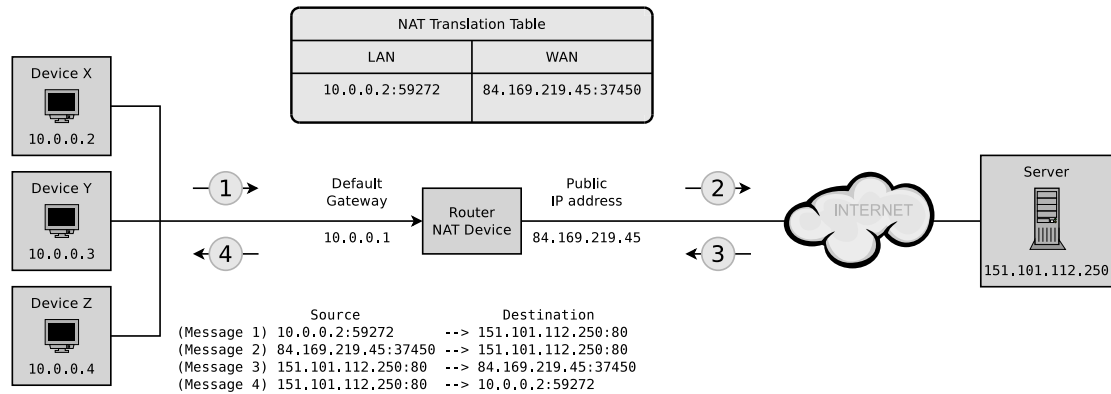

2 Points

- (2) Simplify this IPv6 address:  
 21da:00d3:0000:0000:02aa:00ff:fe28:9c5a  
 Solution: 21da:d3::2aa:ff:fe28:9c5a

2 Points

- (3) Simplify this IPv6 address:  
 2001:0db8:0000:0000:5a6b:0000:0001:678a  
 Solution: 2001:db8::5a6b:0:1:678a

2 Points

- (4) Provide all positions of this simplified IPv6 address:  
 2001:db8:84a2::8a2e:70:4  
 Solution: 2001:0db8:84a2:0000:0000:8a2e:0070:0004

2 Points

- (5) Provide all positions of this simplified IPv6 address:  
 2001:cdba::18:2  
 Solution: 2001:cdba:0000:0000:0000:0000:0018:0002

# Question 6)

Points: ..... of 8

4 Points

- (1) Split the class B network 189.23.0.0 for implementing 20 subnets. Calculate the subnet mask and fill in the missing numbers.

Network ID: 10111101.00010111.00000000.00000000    189.23.0.0  
 Number of bits for subnet IDs: 20 => 32 ( $= 2^5$ ) => 5 bits    (1 point)  
 Subnet mask: 11111111.11111111.11111000.00000000    255.255.248.0    (1 point)  
 Number of bits for host IDs: 11    (1 point)  
 Number of host IDs per subnet:  $2^{11} - 2 = 2046$     (1 point)

4 Points

- (2) Split the class C network 195.3.128.0 into subnets which contain 60 hosts each. Calculate the subnet masks and fill in the missing numbers.

Network ID: 11000011.00000011.10000000.00000000    195.3.128.0  
 Number of bits for host IDs: 60 => 64 ( $= 2^6$ ) => 6 bits    (1 point)  
 Number of bits for subnet IDs:  $8 - 6 = 2$  bits    (1 point)  
 Number of possible subnets:  $2^2 = 4$     (1 point)  
 Subnet mask: 11111111.11111111.11111111.11000000    255.255.255.192    (1 point)

binary representation	decimal representation
10000000	128
11000000	192
11100000	224
11110000	240
11111000	248
11111100	252
11111110	254
11111111	255

# Question 7)

Points: ..... of 9

4 Points

(1) Encode the bit sequence with 4B5B and NRZI and draw the signal curve:

0010 1111 0001 1010

(!!! Use signal level 1 (low signal) as initial signal level of NRZI !!!)

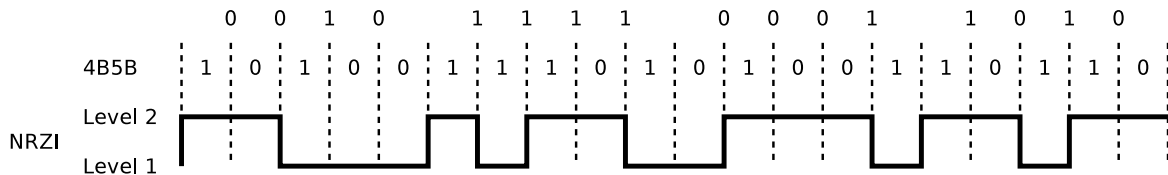

Label	4B	5B	Function
0	0000	11110	0 hexadecimal
1	0001	01001	1 hexadecimal
2	0010	10100	2 hexadecimal
3	0011	10101	3 hexadecimal
4	0100	01010	4 hexadecimal
5	0101	01011	5 hexadecimal
6	0110	01110	6 hexadecimal
7	0111	01111	7 hexadecimal

Label	4B	5B	Function
8	1000	10010	8 hexadecimal
9	1001	10011	9 hexadecimal
A	1010	10110	A hexadecimal
B	1011	10111	B hexadecimal
C	1100	11010	C hexadecimal
D	1101	11011	D hexadecimal
E	1110	11100	E hexadecimal
F	1111	11101	F hexadecimal

5 Points

(2) Encode the bit sequence with 5B6B and NRZ and draw the signal curve.

11010 11110 01001 00010 01110

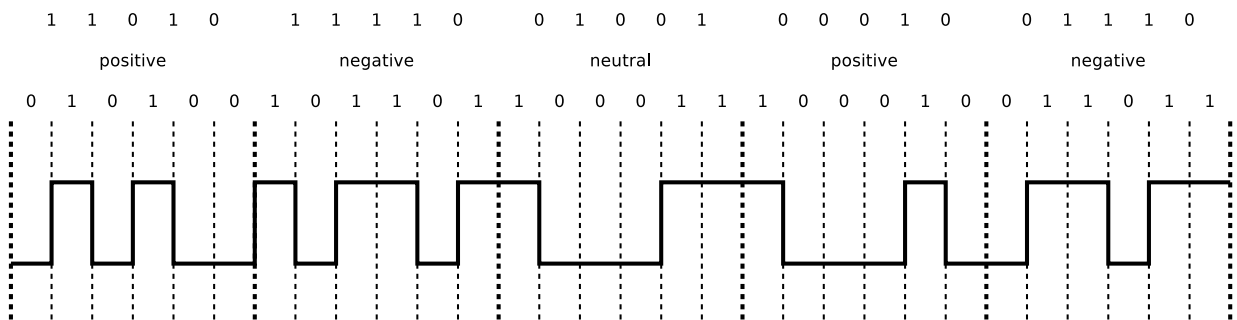

5B	6B neutral	6B positive	6B negative
00000		001100	110011
00001	101100		
00010		100010	101110
00011	001101		
00100		001010	110101
00101	010101		
00110	001110		
00111	001011		
01000	000111		
01001	100011		
01010	100110		
01011		000110	111001
01100		101000	010111
01101	011010		
01110		100100	011011
01111	101001		

5B	6B neutral	6B positive	6B negative
10000		000101	111010
10001	100101		
10010		001001	110110
10011	010110		
10100	111000		
10101		011000	100111
10110	011001		
10111		100001	011110
11000	110001		
11001	101010		
11010		010100	101011
11011	110100		
11100	011100		
11101	010011		
11110		010010	101101
11111	110010		



## Question 8)

Points: ..... of 9

1 Point

- (1) Mark the label of Twisted Pair Cables that have no cable and no pair shielding.
- ATP     FTP     STP     UTP     XTP     ZTP

2 Points

- (2) Explain the meaning of the information 24AWG, 26AWG, and 28AWG on cables and explain the effect on the attenuation and installation.

*American wire gauge (AWG) is a standardized wire gauge system, which is used mainly in the United States and Canada for the diameters of electrically conducting wires.*

*24AWG = 0.51054 mm, 26AWG = 0.405 mm, 28AWG = 0.321 mm*

*Larger wire diameter  $\implies$  less electrical resistance for the electronic signals  $\implies$  lower attenuation.*

*24AWG cables have lower attenuation than 26AWG or 28AWG cables.*

*28AWG cables are thinner than 24AWG or 26AWG.*

*Thinner cables block airflow in server racks less and simplify the installation.*

2 Points

- (3) Explain the meaning of the information SOLID and STRANDED on cables and explain the effect on the installation.

*Solid cables use solid copper wires. Such cables are well suited for permanent infrastructure installation. They have a lower attenuation and cost less compared to stranded cables.*

*Stranded cables consist of multiple strands of wires wrapped around each other. They are typically used to create patch cables because they are very flexible. Attenuation of stranded cables is higher compared to solid cables. Thus, they are used for shorter distances.*

4 Points

- (4) A scientific experiment produces 35 PB ( $35 * 10^{15}$  Byte) of data per year, which need to be stored. Calculate the height of the stack of storage media, if for storing the data CDs with 650 MB ( $650 * 10^6$  Byte) capacity and 1.2 mm thickness are used?

$$\text{Number of CDs:} \quad \frac{35 * 10^{15} \text{ Byte}}{650 * 10^6 \text{ Byte}} = \frac{35 * 10^9 \text{ Byte}}{650 \text{ Byte}} \approx 53,846,154$$

$$\text{Height of the CD stack:} \quad 53,846,154 * 1.2 \text{ mm} \approx 64,615,384.8 \text{ mm} \approx 64.62 \text{ km}$$

## Question 9)

Points: ..... of 7

2 Points

- (1) Name and describe the two special characteristics of the transmission medium in wireless networks that cause undetected collisions at the receiver.

*Hidden terminal problem (problem caused by invisible or hidden terminal device). Because of obstacles, not all stations can detect all transmissions, although they interfere each other at the Access Point.*

*Fading (decreasing signal strength). The electromagnetic waves of the wireless network are weakened by obstacles and in free space. Caused by the positions of stations to each other, their signals are so weak, that the stations cannot detect each others transmissions.*

2 Points

- (2) Name a benefit and a drawback of using the control frames Request To Send (RTS) and Clear To Send (CTS).

*Advantage: It reduces collisions because it solves the problem of hidden terminals.*

*Drawbacks: Delays occur, which are caused by the reservation of the transmission medium. The RTS and CTS frames, which are used to reserve the transmission medium, are overhead.*

1 Point

- (3) Explain what the function of the Address Resolution Protocol (ARP) is.

*The Address Resolution Protocol (ARP) is used to convert IP address of the Network Layer to MAC address of the Data Link Layer.*

1 Point

- (4) Explain what the ARP cache is and why it is used in practice.

*The ARP cache is a table, which contains IP addresses and MAC addresses, that belong together. It is used to speed up the address resolution.*

1 Point

- (5) Explain why loops on Data Link Layer can cause malfunctions in the network.

*Computer networks should always provide only a single path to each possible destination on the Data Link Layer. That is to avoid that frames are duplicated and arrive multiple times at the destination. Loops can reduce the performance of the network or even lead to a network failure.*